

## Area & Volume

1. A mug is in the shape of a cylinder with diameter 10 centimetres and height 14 centimetres.
- Calculate the volume of the mug.
  - 600 millilitres of coffee are poured in. Calculate the depth of the coffee in the cup.

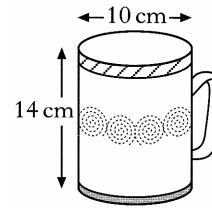

2 KU

3 RE

2. Rainwater is collected in a rectangular based tank on top of a flat roof and is drained periodically to a cylindrical tank on the ground where it is used for watering plants in dry weather.

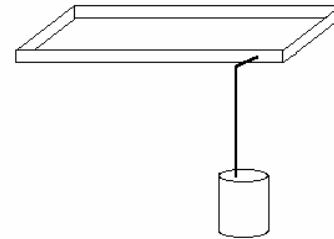

The tank on the roof measures 3 metres by 9 metres and has a depth of 0.25 metres.

The tank on the ground is 1.85 metres high and has base radius of 0.55 metres.

Both tanks were empty, but after a heavy shower all the rainwater from the roof tank was drained to the ground tank and completely filled it.

Calculate the depth of rainwater, to the nearest millimetre, in the roof tank immediately before it was drained to the ground tank.

5 RE

3. A feeding trough, 4 metres long, is prism shaped. The uniform cross-section is made up of a rectangle and semi-circle as shown below.

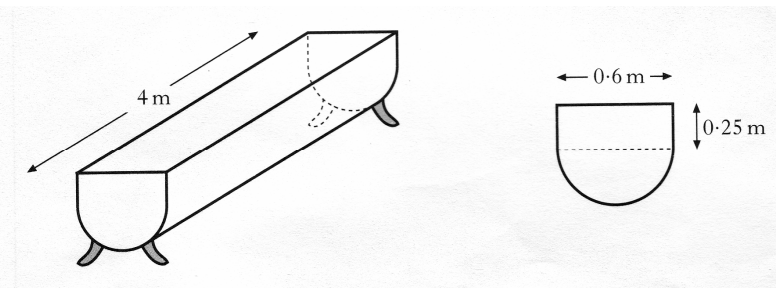

Find the volume of the trough, **correct to 2 significant figures**.

5 KU

4. The diagram shows a horse-shoe magnet.

The face of the arched part at the top consists of two semi-circles, with radii 2 centimetres and 4 centimetres.

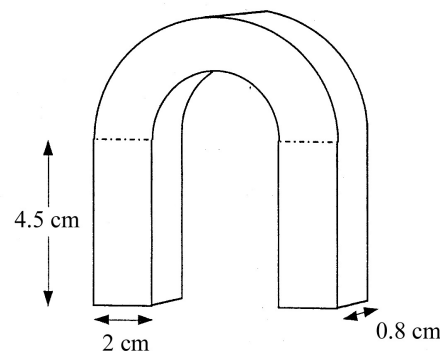
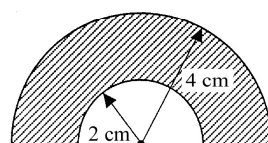

Calculate the shaded area and use this to calculate the volume of metal required to make the magnet.

Give your answer correct to 1 decimal place.

5 RE

5. A cylindrical soft drinks can is 15 centimetres in height and 6.5 centimetres in diameter.  
A new cylindrical can holds the same volume but has a reduced height of 12 centimetres.  
What is the height of the new can ?

Give your answer to **1 decimal place**.

4 RE

6. A metal doorstep is prism shaped,  
as shown in Figure 1  
The uniform cross-section  
as shown in Figure 2:

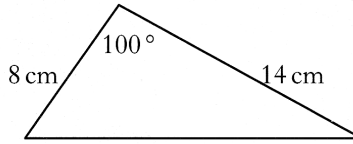

Figure 2

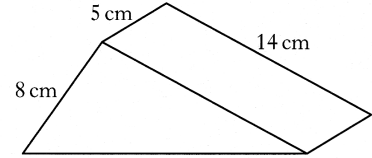

Figure 1

Find the volume of metal required to make the doorstep.

4 KU

7. A glass vase, in the shape of a cuboid with a square base is 20 centimetres high.

It is packed in a cardboard cylinder with radius 6 centimetres and height 20 centimetres.

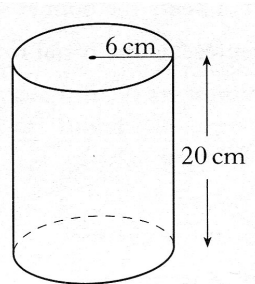

The corners of the vase touch the inside of the cylinder as shown.

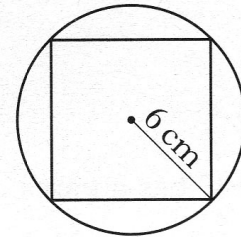

Show that the volume of the space between the vase and the cylinder is  $720(\pi - 2)$  cubic centimetres.

5 RE

8. a) Explain what is wrong with this advert for a 1 litre carton of Orange Juice.

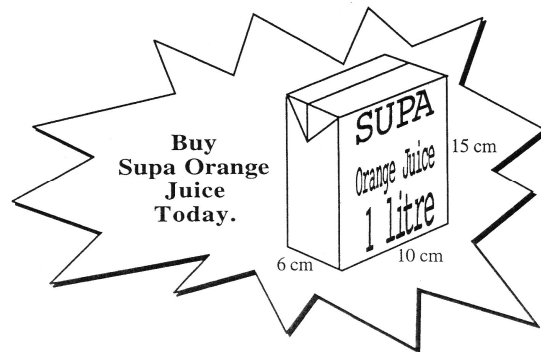

2 KU

- b) The measurements 10 cm, 6 cm and 15 cm are correct.

All of the juice is poured into this cylindrical container with base diameter 12 cm and it is found to exactly half fill it.

Calculate the height of the container.

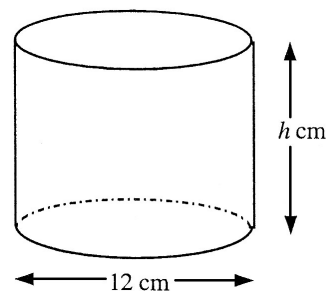

4 RE

9. A wooden toy box is prism-shaped as shown in figure 1.

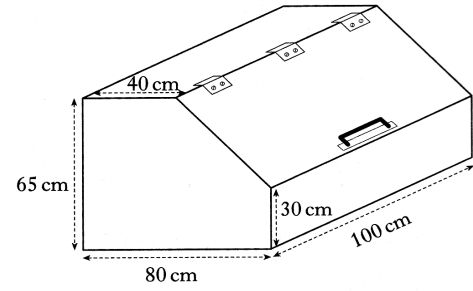

figure 1

The uniform cross-section of the box is as shown in figure 2.

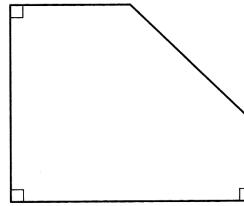

figure 2

Calculate the volume of the box in **cubic metres**.

4 KU

10. A skip is prism shaped as shown in figure 1.

Figure 1.

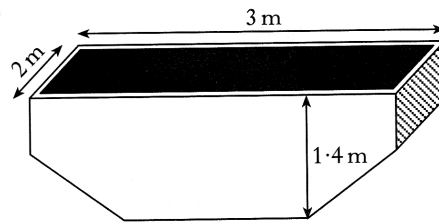

The cross section of the skip, with measurements in metres, is shown in figure 2.

Figure 2.

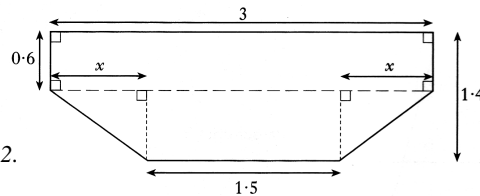

- Find the value of  $x$ .
- Find the volume of the skip in cubic metres.

1 KU

3 KU

11. A storage barn is prism shaped, as shown.

The cross-section of the storage barn consists of a rectangle measuring 7 metres by 5 metres and a semi-circle of radius 3.5 metres.

- Find the volume of the storage barn.  
Give your answers in cubic metres, **correct to 2 significant figures**.

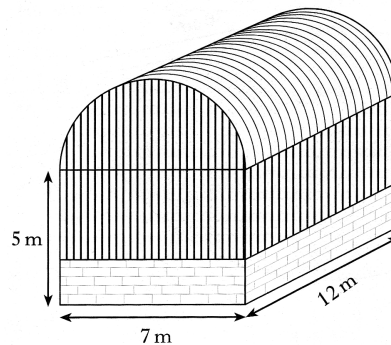

4 KU

- An extension to the barn is planned to increase the volume by 200 cubic metres.

The uniform cross-section of the extension consists of a rectangle and a right angled triangle.

Find the width of the extension.

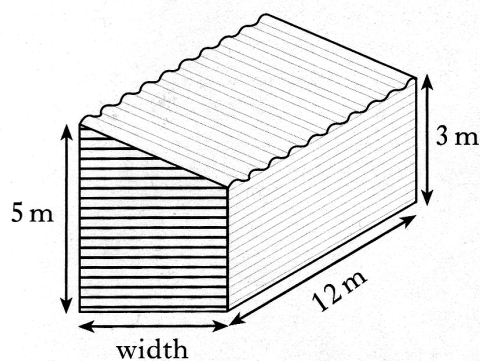

3 RE

12. A ramp is being made from concrete.  
The uniform cross section of the ramp consists of a right angled triangle and a rectangle as shaded in the diagram.

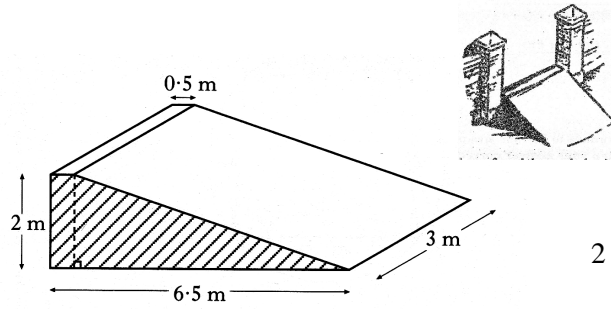

Find the volume of concrete required  
To make the ramp.

2 KU

13. Ground has to be blasted and removed so that a motorway can be widened.  
The existing motorway and the motorway after widening are shown below.

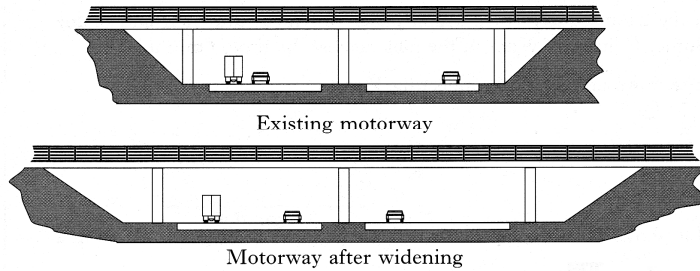

The uniform cross-section of the existing  
motorway consists of a rectangle and two  
congruent right angled triangles  
as shown in figure 1.

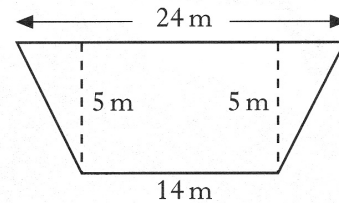

figure 1

The uniform cross-section of  
the motorway after widening  
consists of a rectangle and  
two congruent right angled  
triangles as shown in figure 2.

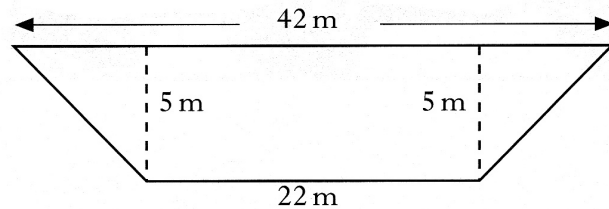

figure 2

The cost of blasting and removing each cubic metre of ground is £4.  
**10 kilometres** of existing motorway is to be widened.  
Find the total cost of blasting and removing the ground.

4 RE

14. A bottle bank is prism shaped,  
as shown in figure 1.

The uniform cross-section  
is shown in figure 2.

Figure 1

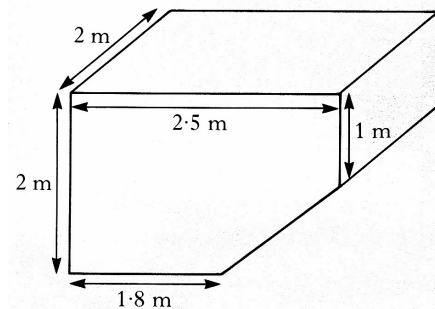
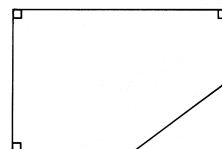

Figure 2



Find the volume of the bottle bank.

4 KU