

C			
F			
E			
L			
E			
V			
E			
L			
3			

CFE Level 3

Homework Pack

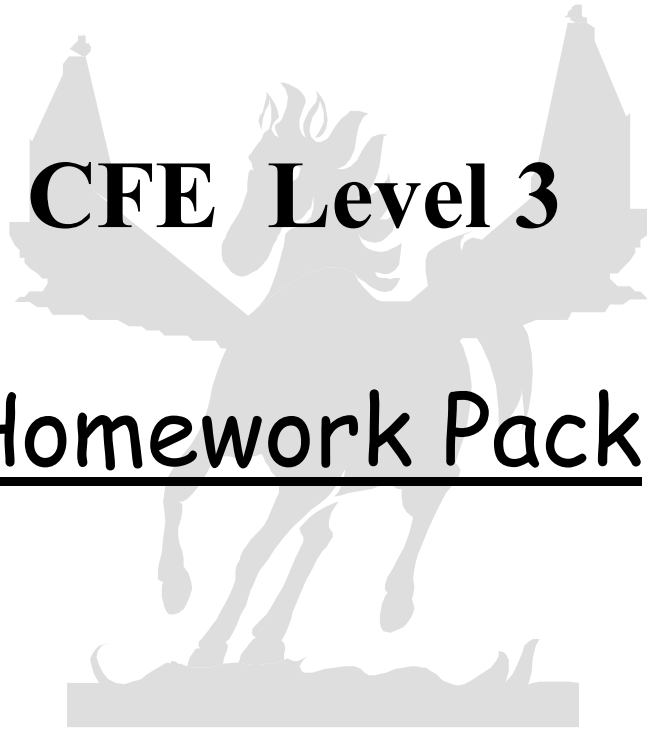

- ❖ Worksheets covering all topics
- ❖ + Answers

Curriculum for Excellence - Level 3 Homework Pack

This pack has been developed in line with the "Experiences and Outcomes" of Curriculum for Excellence and is aimed at young people working at Level 3.

Suitable real life contexts have been used wherever possible in keeping with the ideals of Curriculum for Excellence.

The pack is differentiated across three sub levels to accommodate young people with varying Mathematical abilities. Sub levels and content are detailed below.

The exercises in this pack are differentiated over three sub levels and follow the topics listed below.

Pack contains

- 11 homework exercises at the **Groundwork Sub Level**
- 11 homework exercises at the **Core Sub Level**
- 11 homework exercises at the **Extension Sub Level**

Sub Level descriptions ... **Groundwork** - The content of this is mainly pre Level 3. It is aimed at students who may struggle with the core content of Level 3, but who would be covering the same topics as those on the core Level 3 course.

Core - As its name suggests, this covers the core content of Level 3 with the exception of the most demanding outcomes and experiences.

Extension - Aimed at stretching the more able students with more demanding applications of level 3 content (and very occasional level 4 content). There is an emphasis on problem solving.

The exercises are differentiated over 3 sub levels. These are **roughly** equivalent to students **coming in** at the following 5 – 14 levels.

<u>Sub Level</u>	<u>5 – 14 Equivalence (approx.)</u>
Groundwork	C
Core	D
Extension	E

Exercise Titles (Topics & CFE Outcomes)

Number Processes (Includes Estimation)	MNU 3-03a MNU 3-03b MNU 3-04a (MNU 3-01a)
Data Handling and Analysis	MNU 3-20a MNU 3-20b (MTH 2-21a) / MTH 3-21a
Fractions, Decimals and Percentages	MNU 3-07a MTH 3-07b MTH 3-07c MNU 3-08a
Angle, Symmetry and Transformation Part One	MTH 3-17a (MTH 2-19a) / MTH 3-19a
Expressions and Equations (Includes Powers and Roots)	MTH 3-14a MTH 3-15a MTH 3-15b (MTH 3-06a)
Measurement	MNU 3-11a MTH 3-11b
Angle, Symmetry and Transformation Part Two	MTH 3-17b MTH 3-17c (MTH 2-18a) / MTH 3-18a
Money	MNU 3-09a
Properties of 2D shapes and 3D objects	MTH 3-16a
Time	MNU 3-10a
Factors, Multiples and Primes Ideas of chance and uncertainty Patterns and Relationships Maths – its impact, past, present and future.	MTH 3-05a MTH 3-05b MNU 3-22a MTH 3-13a MTH 3-12a

Level 3 Groundwork Homework
Number Processes

1. Write these numbers in words
a) 3 000 b) 2 437 c) 8 046

2. Write these numbers using digits.
a) Eight thousand.
b) Four thousand, three hundred and forty six.
c) Two thousand and thirty eight.

3. Work out the answers to these **without using a calculator**.
Make sure you write the calculation down correctly.

a) $647 + 321$	b) $858 + 39$
c) $578 - 236$	d) $276 - 148$
e) 27×6	f) $345 \div 5$

4. For each of the following questions, write the correct calculation and work out the answer.

- a) Janet has £857 in her bank account.
She buys a new lap top for £380.
How much is left in her bank account.



- b) Hamish buys 7 pencils.
Each pencil costs 14p.
How much does he spend altogether?



- c) Safi is doing a tour of Scotland.
On Thursday she drives 114 miles
from Duns to Blairgowrie
On Friday, she drives from Perth to
Durness which is 227 miles
How far did she drive altogether in the two days?



5. Write down the answers to these calculations.

a) 74×10

b) 342×10

c) $90 \div 10$

d) $530 \div 10$

6. During winter Cedric notices that on Tuesday the temperature is -2°C .
On Wednesday it is -6°C .
Which day was warmer?



7. Round to the nearest whole number.

a) 5.2

b) 7.8

c) 13.26

8. Round these numbers to the nearest 10.

a) 73

b) 87

c) 238

9. Round these numbers to the nearest 100.

a) 482

b) 247

c) 3 469

Level 3 Core Homework
Number Processes

1. Write these numbers in words.
a) 125 000 b) 235 678 c) 204 038
2. Write these numbers using digits.
a) Two hundred and thirty five thousand.
b) Four hundred and eleven thousand, six hundred and five.
3. Work out the answers to these **without using a calculator**.
Make sure you write the calculation down correctly.
a) $6\ 479 + 3\ 217$ b) $6\ 704 - 4\ 828$
4. Calculate the answer to these, **without using a calculator**.
a) 34×20 b) 7×32
c) 6×29 d) $320 \div 40$
5. For each of the following questions, write the correct calculation and work out the answer.
- a) Heidi is travelling from Earth to the moon which is a distance of 238 855 miles. She has so far travelled 178 469 miles. How far does she still have to go?
- b) Andy drives 540 miles and uses 20 litres of petrol. How many miles did he travel for each litre?



- c) Helen spends £27 on petrol and £12 on parking each week.
How much will this be altogether over a period of 7 weeks.



6. Write down the answer to these.

a) 453×100 b) $123\,400 \div 100$

7. One day the temperatures around the world include:

Prague	0°C	Helsinki	-4°C
Chirnside	2°C	Oslo	-8°C

Write the temperature in order, warmest first.

8. At midnight, the temperature is -6°C
By morning it has risen by 4°C
What is the new temperature?



9. Graham has a balance of £15 in his bank account.
He buys a watch for £20, using his bank card.
What is his new balance?



10. Round the following to 1 decimal place.

- a) 5.72 b) 12.49
c) 24.85 d) 17.3741579

Level 3 Extension Homework
Number Processes

1. Write these numbers in words.
 - a) 8 125 000 b) 3 235 678
 - c) 9 004 038

2. Write these numbers using digits.
 - a) Four million, six hundred and thirty seven thousand.
 - b) Six million, twenty five thousand, six hundred and five.

3. Calculate the answer to these, **without using a calculator**.
 - a) 74×30 b) 9×64
 - c) 8×79 d) $540 \div 60$
 - e) $47 \times 1\,000$ f) $34 \times 2\,000$

4. For each of the following questions, write the correct calculations and work out the answer.
Still no calculator allowed!

- a) Heidi is flying from Earth to the moon which is a distance of 238 855 miles. She is travelling 30 000 miles each day. After 6 days, how far will she still have to travel?



- b) Andy drives 960 miles and uses 80 litres of petrol. How many miles did he travel for each litre?



- c) Helen spends £38 on petrol and £18 on parking each week.
How much will this be altogether over a period of 8 weeks?



- d) Bogtown Rovers attendance receipts for a match are £2 192.
The prices are children £8 and adults £20.
If 79 children were at the match, how many adults were there?



5. Boris in Moscow phones his friend Sigfried in Vienna.
Boris tells Sigfried that the temperature in Moscow is -17°C .
"It is warmer by 14°C here" says Sigfried laughing.
However later that night the temperature in Vienna has fallen by 6°C .
What is the new temperature in Vienna ?

6. Calculate.

a) $-2 + 9$ b) $-11 + 4$ c) $-80 + 17$
d) $6 - 11$ e) $-3 - 14$ f) $-12 - 89$

7. Round the following to 1 decimal place.

a) 12.381266 b) 19.962144

8. Round the following to 2 decimal places.

a) 16.357123 b) 19.3971554

Level 3 Groundwork Homework

Data Handling

1. Class 1R carried out a survey of the colours of car in the local car park.
Results are as follows:



Red	Blue	Silver	Blue	Red
Black	Green	Red	Silver	Blue
Green	Silver	Blue	Black	Green
Silver	Red	Red	Blue	Red
Green	Red	Blue	Green	Silver
Red	Blue	Silver	Silver	Black

- a) Copy and complete this frequency table to show the results:

Colour	Tally	Frequency
Red		
Blue		
Black		
Green		
Silver		

- b) Show your results in a bar chart.
c) What is the most popular colour of car?
2. The bar graph shows the favourite subjects of S1 pupils.

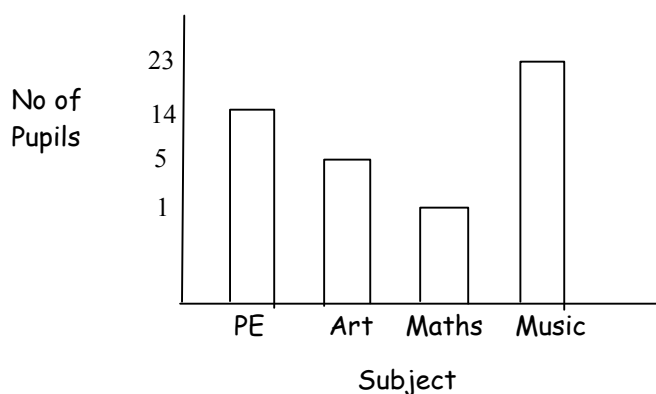

Can you see a mistake in the graph that makes it misleading?

3. The pictograph below shows how students travel to school in a city.

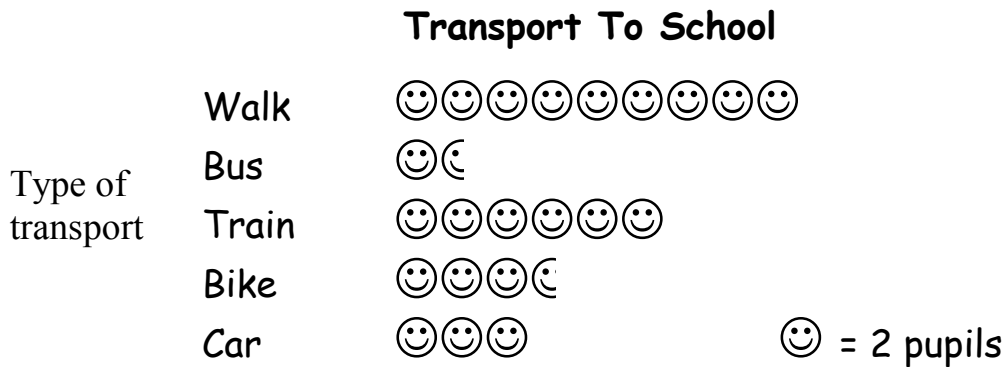

- a) How many pupils walk to school?
- b) How many more take the train, than the bus?
- c) Do you think that the results would be similar in all schools?
What may be different?

4. Five athletes see how many press ups they can manage. The results are as follows:

80 65 35 70 50



- a) Calculate the mean amount of press ups.

Five players from the local pub domino team see how many press ups they can manage.

- b) Do you think the mean for the domino players will be higher or lower than the athletes?
Give a reason.

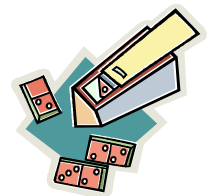

Level 3 Core Homework
Data Handling

1. A class are asked how many items of fruit or vegetables they eat in a day.
The responses are listed below.



2 3 4 1 0 5 4 6 4 2
3 0 4 1 1 2 4 5 5 2
1 3 1 2 5 6 0 2 4 5

- a) Draw a frequency table to show these results.
 - b) Use your frequency table to draw a bar graph.
 - c) It is recommended that you eat at least 5 items of fruit or vegetables each day.
Comment on how this applies to the results here.
 - d) Is there anything to consider when collecting the data here?
2. A survey on canteen was carried out with the pupils in the canteen one day.
The results were as follows.

	No. of Pupils
Enjoy all of the canteen meals	24
Enjoy most of the canteen meals	19
Enjoy some of the canteen meals	11
Do not like canteen meals	3

- a) Draw a pictograph to show the results.
- b) Do you think that these results are **robust**?
Give a reason for your answer.

3. A film critic is keen to find out what age group goes to the cinema most often. He goes along on Saturday night and asks people in the queue what age they are. The results are shown in the Pie Chart below.

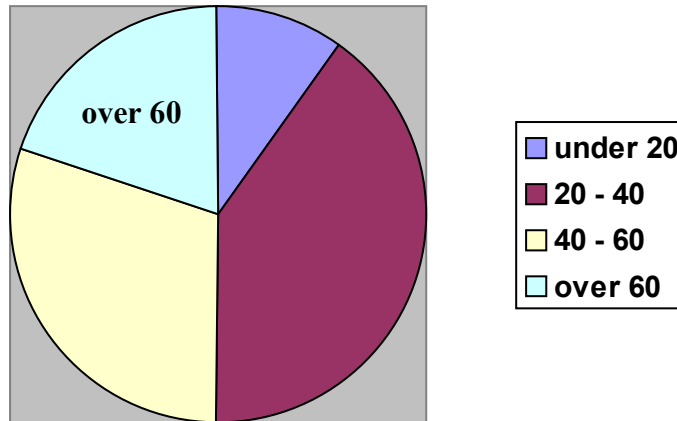

The critic thinks that this proves that most people who go to the cinema are in the 20 - 40 age group.

- a) Do you agree with his statement?
b) Can you see any reasons why his results may be misleading?
4. a) The ages of a group of friends are 26, 32, 47, 28 and 37. Calculate the mean age.
b) In another group Amy is 19 Tina is 32. Along with their friend Senga, their mean age is 30. What is Senga's age?



Level 3 Extension Homework
Data Handling

1. An online poll is carried out to find out how many hours children spend on the internet each week.



Results are shown below:

No. of Hours	No. of Children
0 - 10	7
11 - 20	21
21 - 30	38
over 30	24

- a) Draw a pie chart to illustrate these results.
Show clearly the calculations to find the correct angle for each sector.
- b) Do you think that these results are robust data?
Give reasons for your answer.
2. Robust, vague, misleading and unprejudiced are all words that can be used when analysing data.
Write down what you believe is the meaning of each, giving an example if you wish.

3. A telephone poll is carried out to judge the goal of the season in Scotland.

Nominations are:

Black - Rangers, Green - Hearts,

Britton - Partick Thistle and

Brown - Greenock Morton

This Pie Chart displays the results.

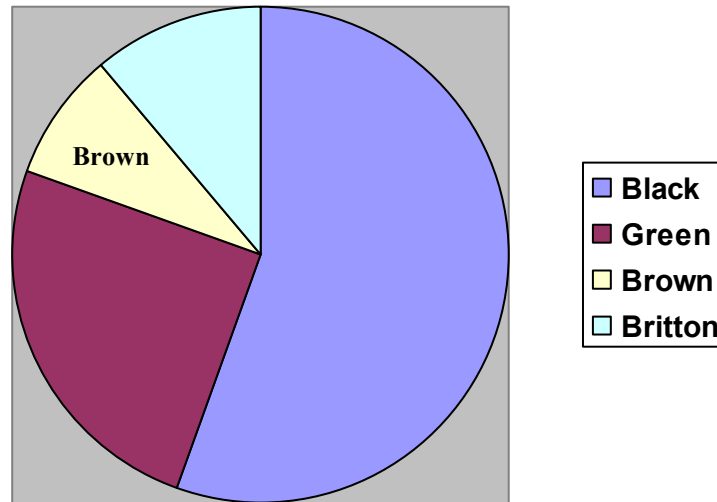

Altogether 1 800 people responded to the poll.

How many people voted for

- Green?
- Black?
- It was hope that this polling method would be the fairest way of choosing the best goal.

Can you see any source of bias in the sampling method used?

4. The test results for a group of pupils are shown below:

35 27 48 27 13 36

- Calculate the mean score.
- A new pupil joins the group and the mean result changes to 33.

What test result did the new pupil get?

Level 3 Groundwork Homework
Fractions, Decimals and Percentages

1. What fraction of the fruits below are apples?



2. Calculate the following.

a) $\frac{1}{2}$ of 18 b) $\frac{1}{3}$ of 15 c) $\frac{1}{4}$ of 20

3. Anwar buys 24 eggs.
Sadly he breaks $\frac{1}{4}$ of them on the way home.
How many **unbroken** eggs does he have?

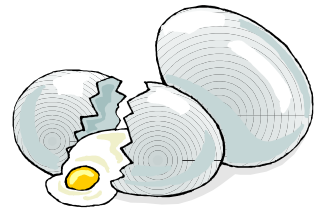

4. Write these percentages as fractions.

a) 50% b) 25% c) 27%

5. Change these percentages to decimals.

a) 43% b) 30% d) 3%

6. Change these decimals to percentages.

a) 0.57 b) 0.02 c) 0.6

7. Calculate



a) 50% of 18 b) 25% of 40 c) 10% of 70

8. Lucinda is out for a meal.
She decides to give the waiter a 10% tip.
Her meal cost £60.
How much should the tip be?



9. Calculate, showing how you got your answer.



- a) 14% of 350 b) 35% of 380 c) 4% of 650

10. The population of Sometown is 2 800.
42% of the population are men.
How many females are in Sometown?

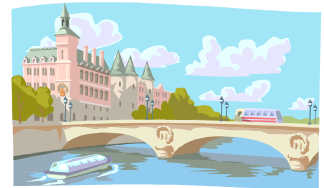

11. Percy's heart beats 78 times in one minute.
How many times will it beat in 10 minutes?



12. Petula's is buying a new car.
When she asks how much petrol it will use,
she is told 42 miles per gallon.
How far will she be able to travel with
5 gallons of petrol?



Level 3 Core Homework
Fractions, Decimals and Percentages

1. What fraction of the fruits below are apples?
Write your answer in the simplest form.



2. Simplify the following fractions:

a) $\frac{4}{14}$ b) $\frac{10}{15}$ c) $\frac{24}{32}$

3. Which of these fractions have the same value?

$\frac{4}{10}$ $\frac{6}{12}$ $\frac{2}{5}$ $\frac{6}{10}$

4. Calculate the following:

a) $\frac{1}{7}$ of 28 b) $\frac{2}{3}$ of 24 c) $\frac{3}{5}$ of 45

5. Anwar buys 24 eggs.
Sadly he breaks $\frac{3}{4}$ of them on the way home.
How many **unbroken** eggs does he have?



6. Write these as Decimals.

a) 70% b) 3% c) $\frac{3}{20}$ d) $\frac{7}{8}$

7. Change these as percentages

a) 0.36 b) 0.9 c) $\frac{7}{10}$ d) $\frac{5}{8}$

8. Write these as fractions:

- a) 17% b) 45% c) 0.27 d) 0.38

9. Calculate



- a) 30% of 70 b) 5% of 420 c) 15% of 70

10. Lola earns £2 460 every month.
She gets a pay rise of 4%.
What will her new monthly pay be?



11. Calculate, showing how you got your answer.



- a) 14% of 350 b) 35% of 380 c) 4% of 650

12. The population of Sometown is 2 800.
42% of the population are men.
How many females are in Sometown?

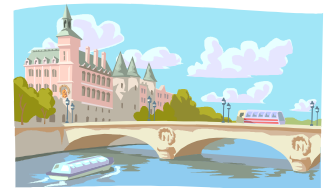

13. Percy's heart beats 243 times in 3 minutes.



- a) Calculate Percy's heart rate per minute.
b) How many times will it beat in 10 minutes?

14. Petula's car uses 7 gallons of petrol to drive
266 miles.

- a) Calculate her fuel consumption in miles
per gallon.



- b) How far can she travel with 11 gallons of petrol?

Level 3 Extension Homework
Fractions, Decimals and Percentages

1. Find three other fractions that are equivalent to $\frac{12}{20}$.
2. Write as fractions:
 - a) $3\frac{2}{3}$ b) $5\frac{3}{7}$
3. Write as mixed numbers:
 - a) $\frac{14}{9}$ b) $\frac{24}{5}$
4. Calculate
 - a) $\frac{1}{8} + \frac{3}{4}$ b) $\frac{9}{10} - \frac{3}{5}$ c) $\frac{3}{4} + \frac{5}{6}$
5. Convert to a decimal:
(Give your answer to 2 d.p. where appropriate)
 - a) $\frac{13}{21}$ b) 4.6% c) $12\frac{1}{2}\%$
6. Convert to a percentage
(Give your answer to 1 d.p. where appropriate)
 - a) $\frac{23}{32}$ b) 0.174 c) 0.042
7. Convert to a fraction.
 - a) 14% b) 3.5% c) 0.04 d) 0.0025

8. Calculate



- a) 4% of 700 b) 16% of 80 c) $17\frac{1}{2}\%$ of 80

9. Calculate



- a) 3.2% of £160 b) 2.4% of £12
c) $3\frac{1}{2}\%$ of £3.42

10. Belinda is going to Italy on holiday.
She changes £200 into euros at an
exchange rate of £1 = €1.22.
She has to pay a charge of 3.2%.
How much will she receive in Euros?

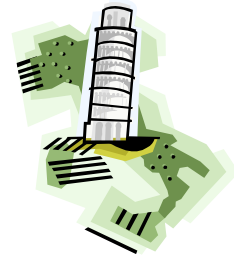

11. Charlie has £840 in his bank account.
He receives interest at a rate of 2.3% p.a.
(per annum - yearly!)
How much interest would he receive if he
withdrew his money after seven months?



12. Cecil is making soup for himself and his
six friends.

He is using the following recipe.

Yummy Soup (serves 4)

Stock 1.2Litres

Mixed Veg. 300g

Chuck all ingredients in pot, bring to the boil,
simmer for 30 minutes and hope for the best.



- a) How much stock and mixed veg. should he use?
(Bear in mind he is very fussy and wants to have the
correct amount, without having any left over)
- b) How long should he simmer it for?

Level 3 Groundwork Homework
Angles, Symmetry and Transformation 1

1. The size of some angles are listed below.
Select the type of angle each is from the following list:

Obtuse Right Straight Acute

- | | | | |
|----|-------------|----|------------|
| a) | 180° | b) | 78° |
| c) | 143° | d) | 90° |

2. Name the angles marked below and state what type of angle they are.

a)

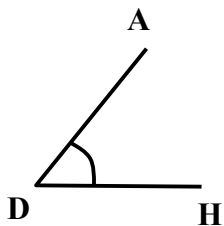

b)

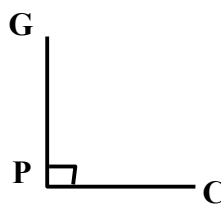

c)

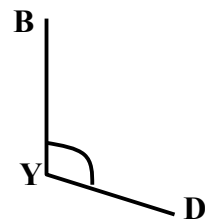

3. **Estimate** the size of the two angles below:

a)

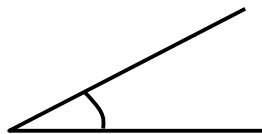

b)

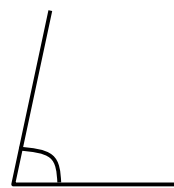

4. **Without measuring**, sketch angles that will be estimates of these sizes.

a) 100°

b) 170°

5. Copy and complete these shapes around the line of symmetry.

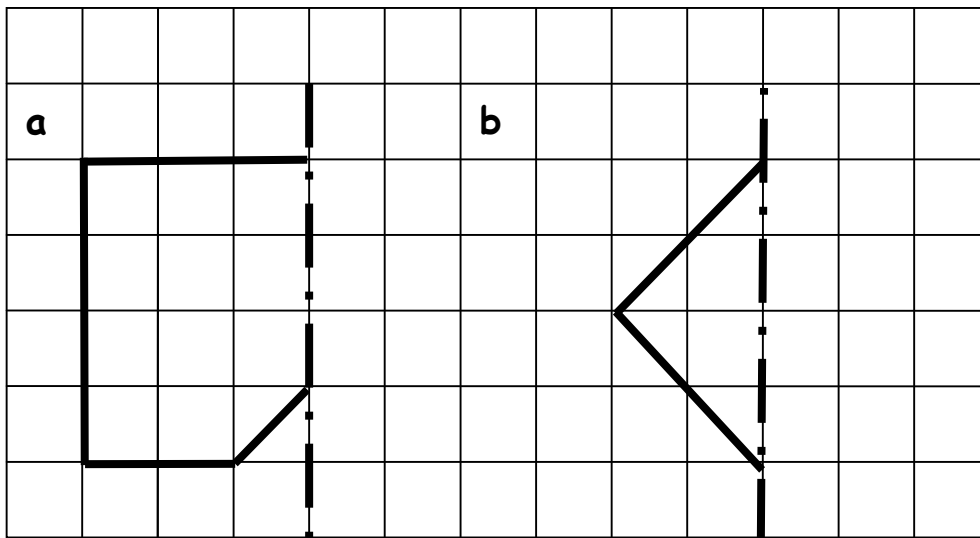

6. Make a copy of each of these shapes and draw in all lines of symmetry (if any).

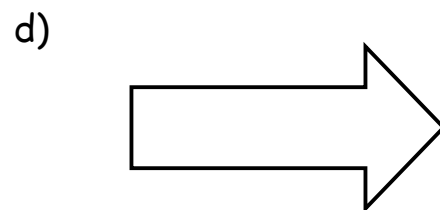
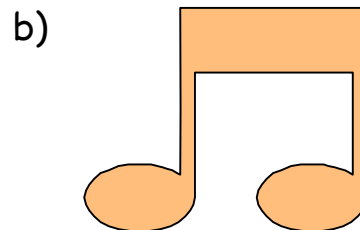
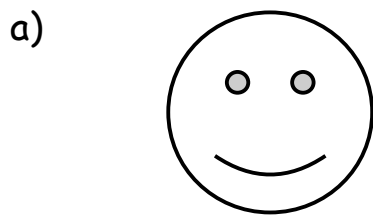

Level 3 Core Homework
Angles, Symmetry and Transformation 1

1. Name the angles marked below and state what type of angle they are.

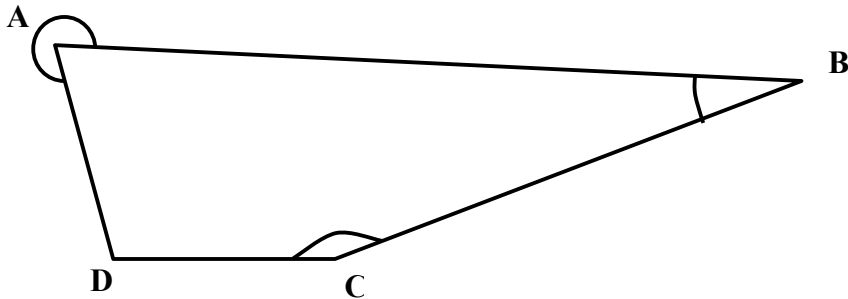

In questions 2 - 5, write down the calculations you carried out to find the answers

2. In the diagram below, $\angle PHY$ is a right angle. If $\angle PHG$ is 65° , calculate the size of $\angle GHY$.

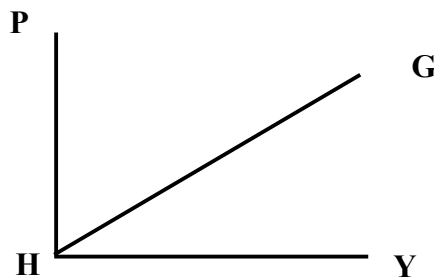

3. If $\angle TBM$ is 48° , calculate the size of $\angle TBD$.

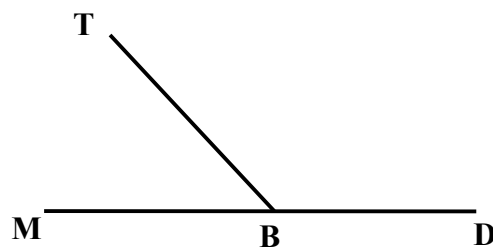

4. In diagram below, $\angle MKP = 75^\circ$.
Name and calculate the size of the other angles in the diagram.

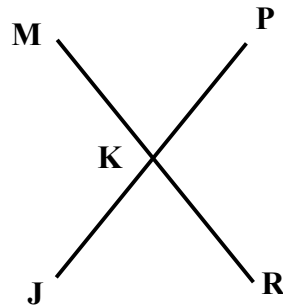

5. Calculate the size of the missing angle in each of these shapes.

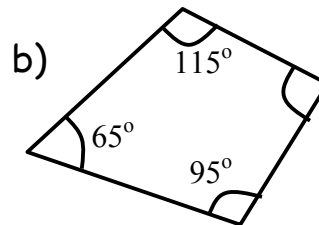
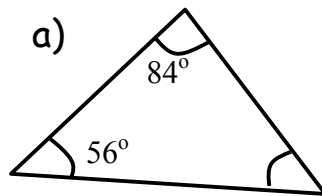

6. Copy the diagram below and fill in all the missing angles.

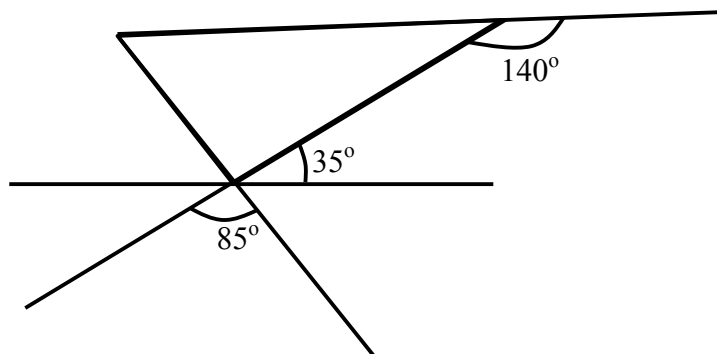

7. Copy and complete these shapes around the line of symmetry.

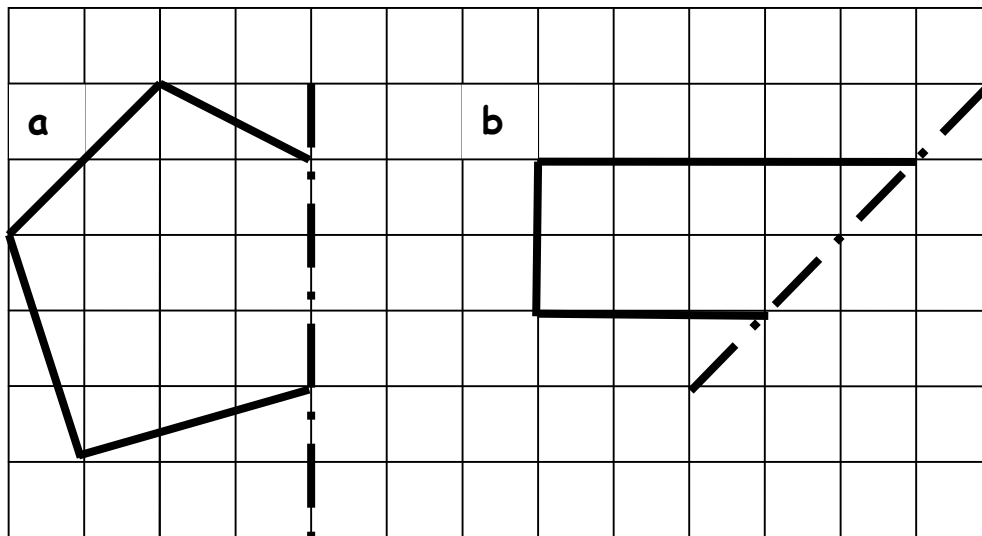

8. Make a copy of each of these shapes and draw in all lines of symmetry (if any).

a)



b)

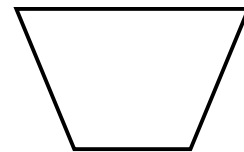

c)



d)

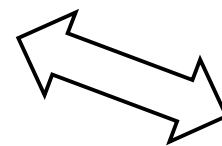

e)

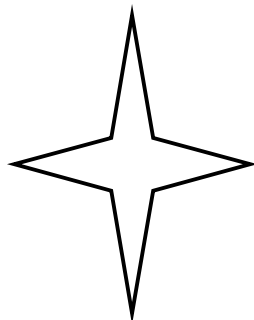

f)

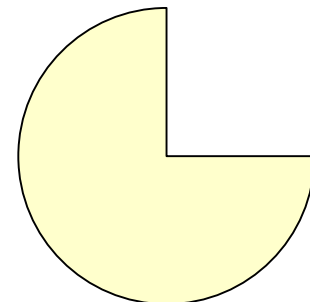

Level 3 Extension Homework
Angles, Symmetry and Transformation 1

1. Name the angles marked below and state what type of angle they are.

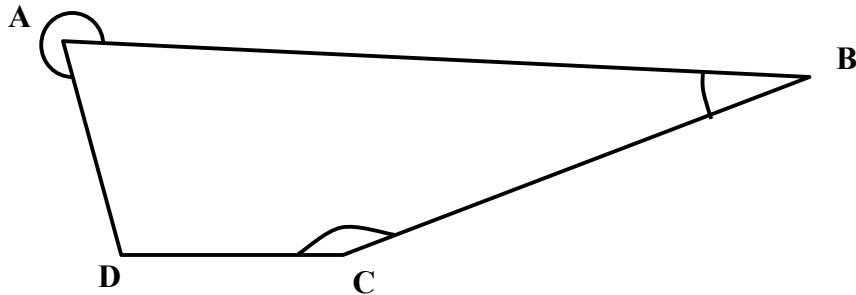

2. In diagram below, $\angle MKP = 75^\circ$. Name and calculate the size of the other angles in the diagram.

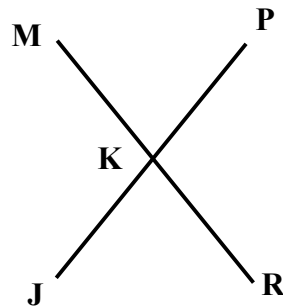

3. Calculate the size of the other angles in each of these shapes.

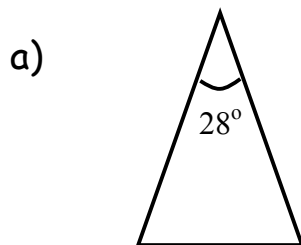

Isosceles Triangle

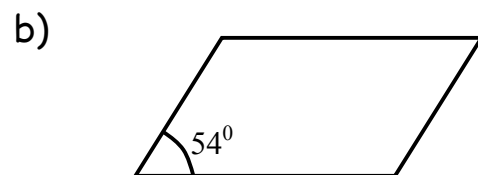

Parallelogram

4. Copy the diagrams below and fill in the missing angles.

a)

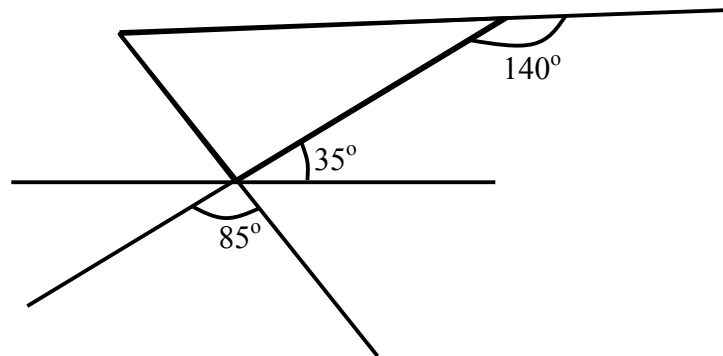

b)

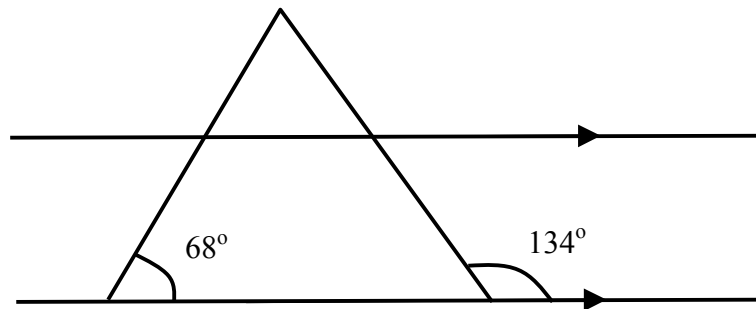

5. The diagram below shows a regular octagon. Find the size of the angle marked y° , showing clearly how you got your answer.

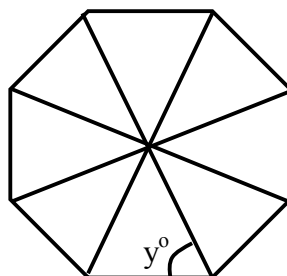

6. a) Angles a° and b° are complementary.
 a° is twice the size of b° .
 Find the size of each.

b) Angles c° and d° are supplementary.
 c° is nine times the size of d° .
 Find the size of each.

7. Copy and complete these shapes around the line(s) of symmetry.

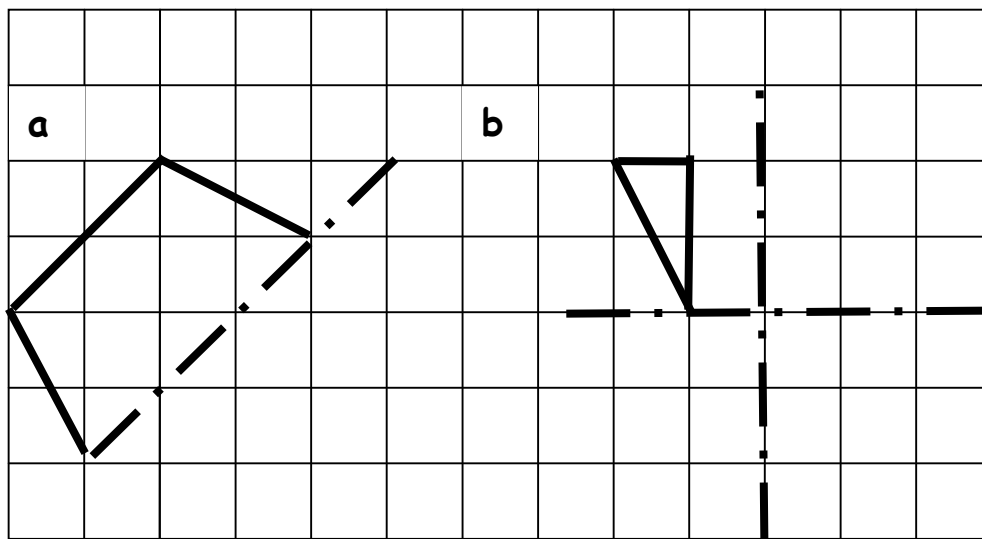

8. Draw an accurate diagram of a shape with exactly three lines of symmetry, clearly showing the lines of symmetry.

Level 3 Groundwork Homework
Expressions and Equations

1. Write in the simplest form.
(The first one is done for you)

a) $2a + 3a = 5a$ b) $4b + 6b$
c) $5d + 2d + 4d$ d) $8t - 3t$
e) $5y - 2y + 3y$ f) $4r + 3r + 6b$ (careful!)

2. A short way to describe this picture would be $3a + 2b$.
Do the same for these pictures.

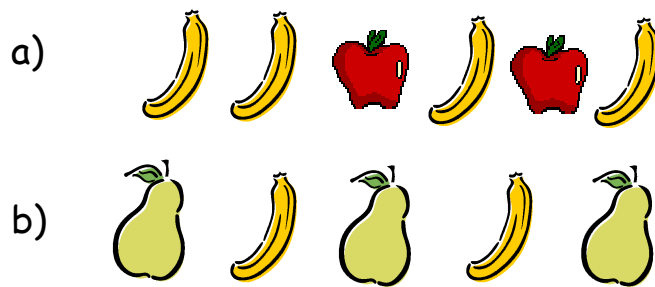
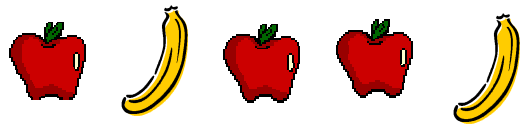

(Pears in this question)

3. Letters are given these values

$a = 3$ $b = 5$ $c = 6$ $d = 10$

so $a + b$
 $= 3 + 5$
 $= 8$

Do the same for these.

a) $b + d$ b) $c - b$ c) $a + d - c$

4. Find the value of the letter in these sequences.
(Write your answer in the form $h =$)

- a) 2 4 6 h 10
- b) 5 10 w 20 25
- c) 18 15 12 n 6
- d) 1 7 s 19 25

5.

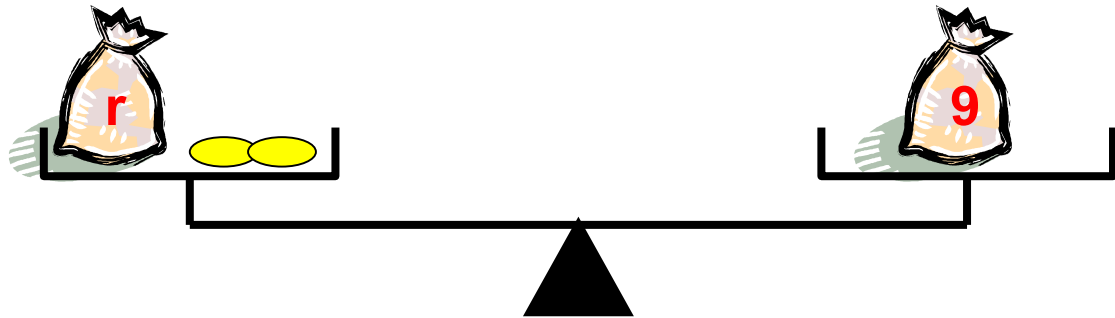

The diagram above could be written as

equation $r + 2 = 9$

solution $r = 7$

Do the same for the diagram below:

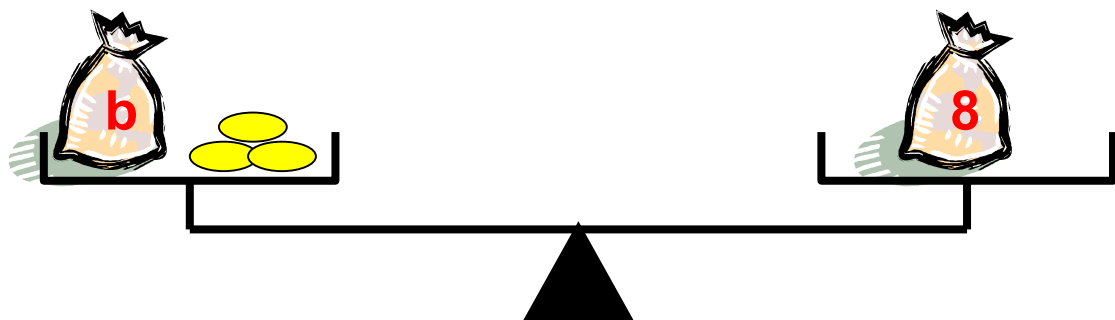

6. Solve these equations.
(Write your answers in form $p =$)

a) $p + 3 = 5$

b) $y + 6 = 10$

c) $f - 2 = 5$

d) $4 \times t = 12$

Level 3 Core Homework Expressions and Equations

1. The amount of coins in each bag is stated on the front. Write an expression to show how many coins are in each picture.

a)



b)



2. There are h passengers on a bus.
At the first stop, 5 more people get on.

- a) Write an expression to show how many people are now on the bus.



At the second stop, 3 people get off.

- b) Write an expression to show how many people are on the bus after this.

3. Write an expression to show what comes out

a)

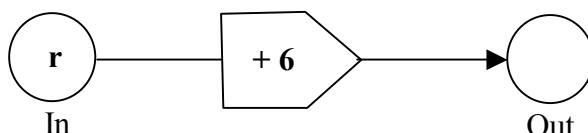

b)

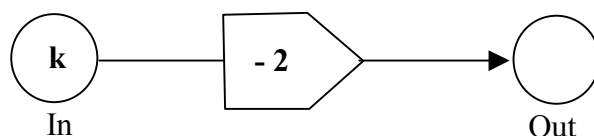

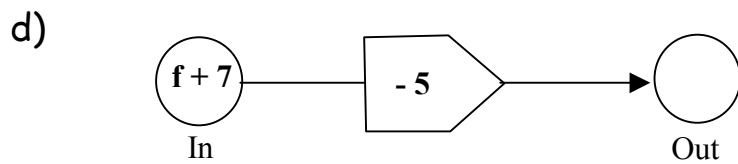
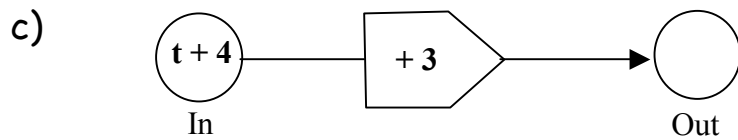

4. Write an equation for each of these diagrams, then solve to find how many coins are in each bag.

a)

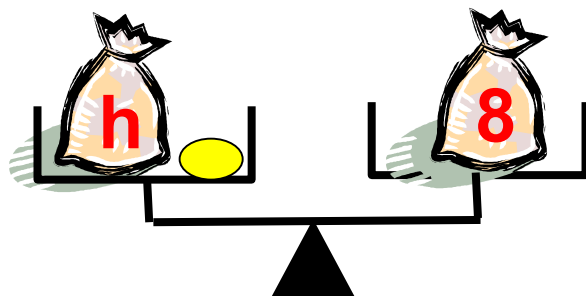

b)

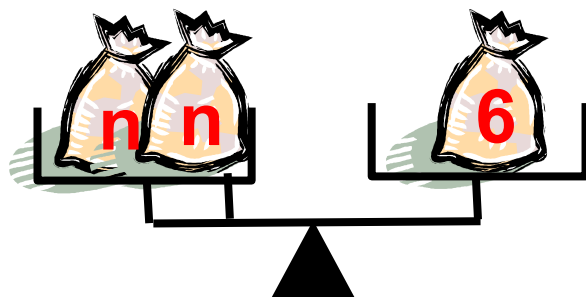

5. Solve these equations:

a) $t - 4 = 7$

b) $3t = 18$

c) $2t + 1 = 11$

d) $3a - 1 = 14$

6. Find the value of these expressions when

$$m = 3 \quad t = 5 \quad r = 6 \quad s = 2$$

(Remember to set it out properly)

a) $m + r$

b) $3t$

c) ms

d) $5m - 4s$

7. For each of these write a formula that would calculate the first thing mentioned (in bold type)

- a) How many **legs (L)** a number of camels (c) have.
(Assume they all have four legs!)
(Hint, Start with $L =$)

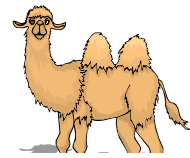

- b) How many **minutes (m)** in a number of hours (h).



- c) How many **weeks (w)** in an amount of days (d).



8. Calculate the value of G in each case for these formulas:
(Still remembering to set it out properly!)

a) $G = 5t$

$t = 7$

b) $G = 7r - y$

$r = 4$

$y = 12$

c) $G = \frac{K}{A}$

$K = 36$

$A = 9$

d) $G = p^2 + 3T$

$p = 4$

$T = 5$

Level 3 Extension Homework Expressions and Equations

1. Write an expression to describe each diagram:



- a) f coins in each bag.
How many coins altogether?



- b) t litres in each carton.
200 ml have been poured from one of the cartons.
How many litres altogether?

2. There are h passengers on a bus.
After the first stop, the number of people on the bus has doubled.



- a) Write an expression to show how many people are now on the bus.

At the second stop, 3 people get off.

- b) Write an expression to show how many people are on the bus at this point.

At the next stop, 2 people get on and 7 people get off.

- c) Write an expression to show how many people are on the bus after this.

3. Write an expression to show what comes out

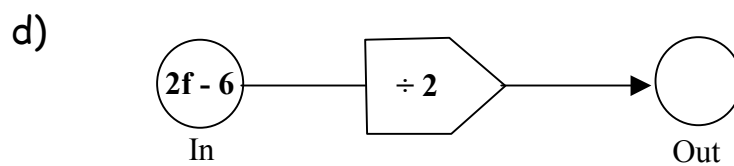
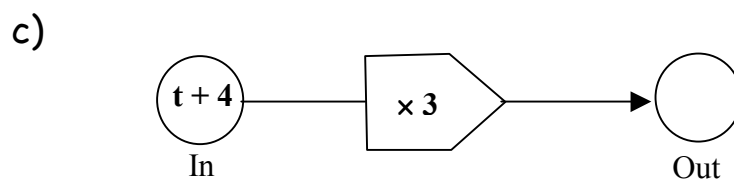
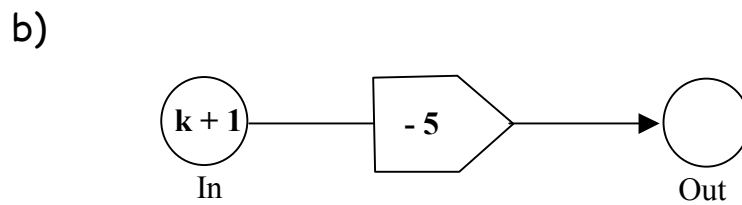
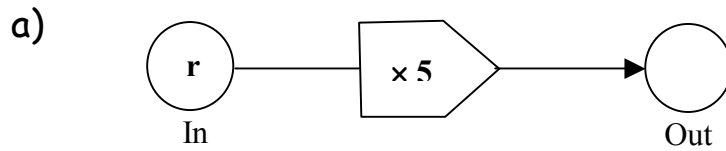

4. Write an expression to show what goes in.

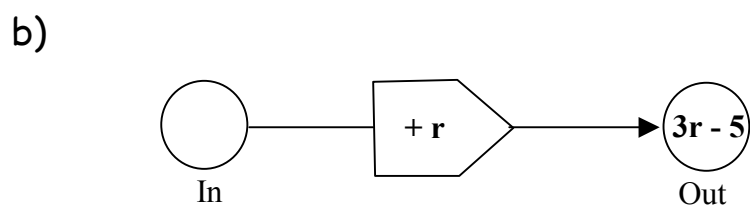
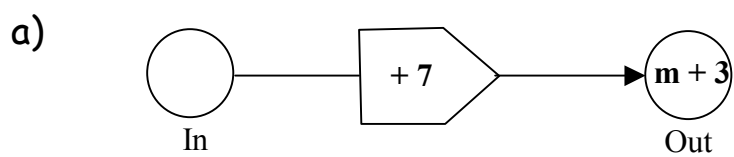

5. a) Four identical boxes are sitting on a shelf.
There is 20 cm of space left on the shelf.



- i) Form an equation where each box is x cm wide and the total length of the shelf is 80 cm.
ii) Solve the equation to find the width of one box.
- b) The total length of wood used to frame this picture is 146 cm

33 cm



$4x$ cm

- i) Form an equation and find the value of x .
ii) What is the height of the frame?

6. Solve these equations:

a) $2t + 1 = 11$

b) $3a - 1 = 14$

c) $19 + 7y = 75$

d) $\frac{1}{2}g - 12 = 8$

7. Find the value of these expressions.

$$m = 3 \quad t = 5 \quad r = 6 \quad s = 2$$

(Remember to set it out properly)

a) $7m + 4r$

b) $mr - ts$

c) $\frac{tr}{5}$

d) $r^2 - mr$

8. Write formulas to represent these situations:

a) Rule to change to Degrees Fahrenheit (F) is to double degrees Centigrade (C) and add 30.

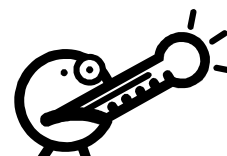

b) Bill (B) for an electrician is £20 per hour plus a call out charge of £30.

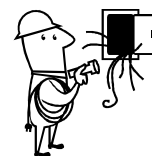

c) Wages (W) that Janet will get if she has been promised £100 for night's work, but has to pay £4 for each broken dish.



9. Calculate the value of G in each case for these formulas:
(Still remembering to set it out properly!)

a) $G = t + 7r$

$t = 6 \quad r = 8$

b) $G = 7r - y$

$r = 4 \quad y = 12$

c) $G = \frac{K}{A}$

$K = 36 \quad A = 9$

d) $G = p^3 - \sqrt{q}$

$p = 4 \quad q = 16$

Level 3 Groundwork Homework
Measurement

1. 5 lengths are listed below.
Choose which one goes with each of the measurements .

110m 67km 12cm 7mm 4m

a) Distance between Edinburgh and Glasgow.

b) Length of an ant.



c) Length of a pencil.



d) Length of a football pitch.



e) Length of a car.



2. Calculate the area of these rectangles.
(Remember to show your working)

a)

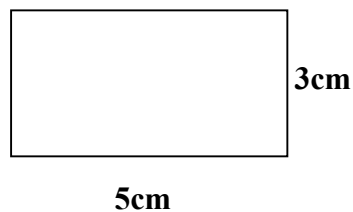

b)

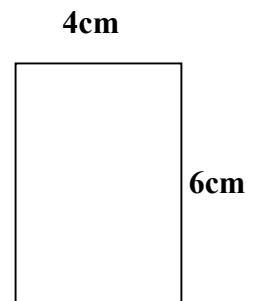

3. Calculate the area of these triangles.
(remember the triangle is **half** the area of the rectangle)

a)

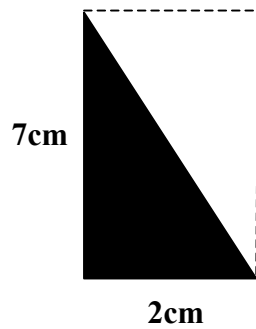

b)

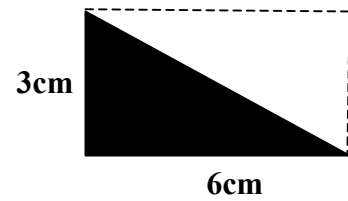

4. Choose the correct area for each of these

a) snooker table

7 m² or 1m²?



b) classroom

70m² or 10m²?



5. Calculate the volume of these cuboids.
(Working!)

a)

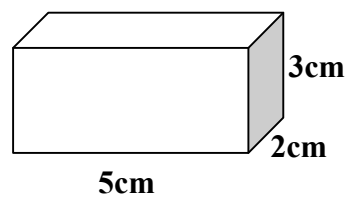

b)

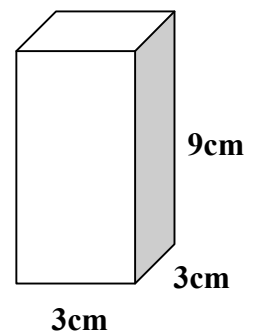

6. Choose the correct volume for each of these

a) Glass

250ml or 250L?



b) Petrol in a car

60L or 500L?



7. The dimensions of a fish tank are shown below:

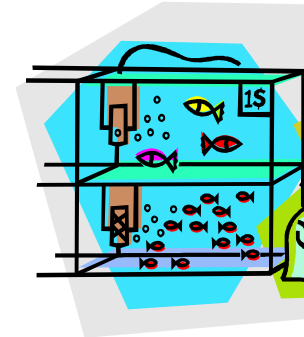
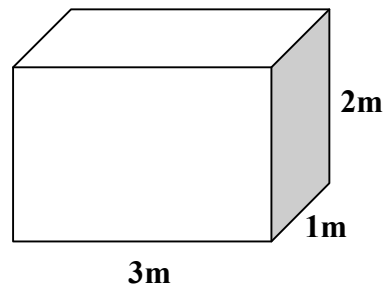

If the tank is **half** full, how much water is in it?

Level 3 Core Homework
Measurement

You must show your working for all questions

1. Calculate the area of the shapes below.

a)

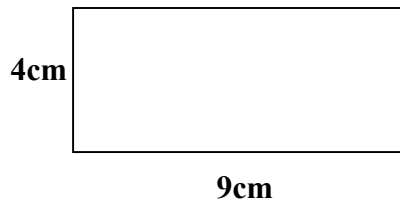

b)

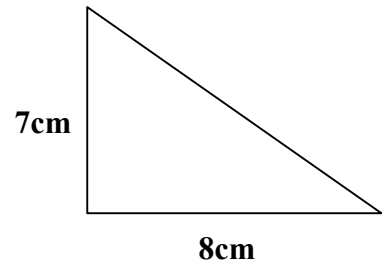

2. Make a sketch of these, then split them up into separate shapes so that you can calculate the total area.

a)

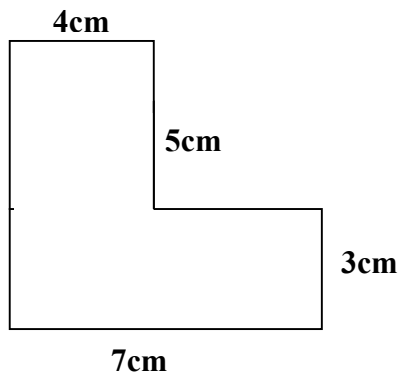

b)

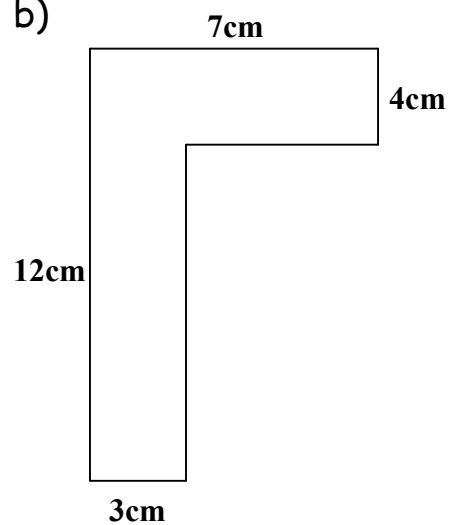

3. Calculate the volume of these cuboids.
(b is a cube)

a)

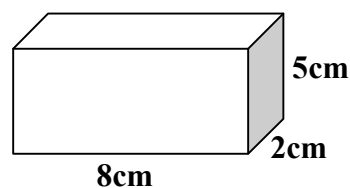

b)

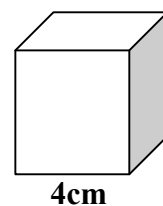

4. A plan of Penelope's garden is shown below. She aims to seed the area with grass except for the two rectangular flower beds shown (which are the same size)

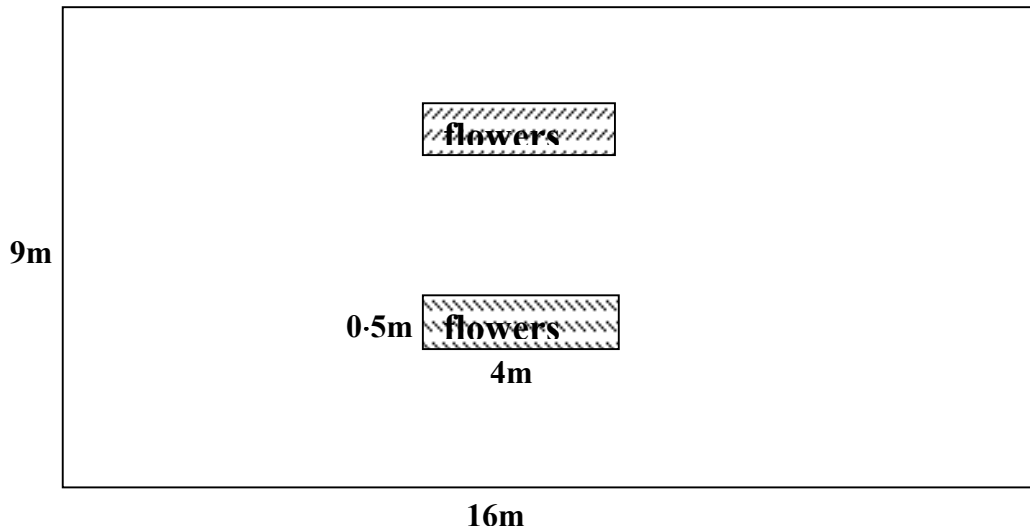

- a) Calculate the area of grass in the garden.
- b) Each bag of grass seed covers 25m^2 and costs £3.50.
How much will it cost Penelope to seed her lawn?
5. The dimensions of a fish tank are shown below:

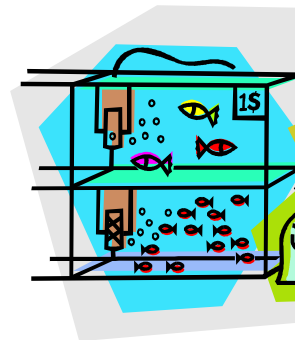
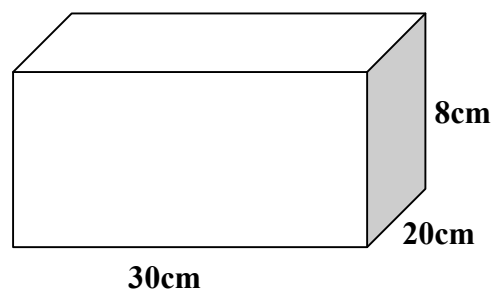

- a) Calculate the volume of the tank in **litres**.
- b) If the tank is $\frac{3}{4}$ full, how much water is in it?

Level 3 Extension Homework
Measurement

You must show your working for all questions

1. Calculate the area of the shapes below.

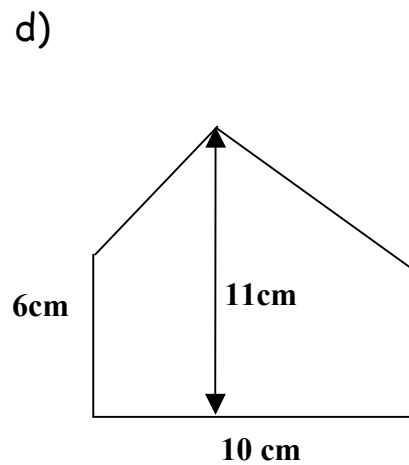
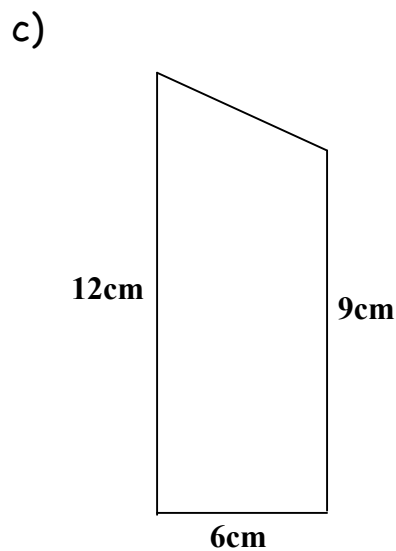
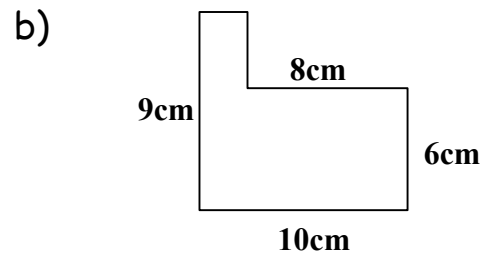
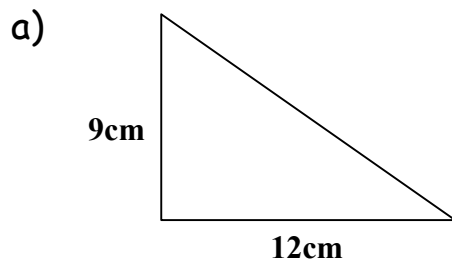

2. Calculate the volume of these cuboids (b is a cube) giving your answers in litres.

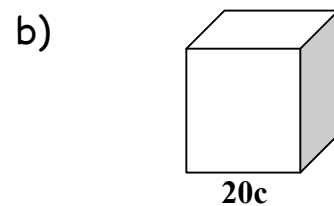
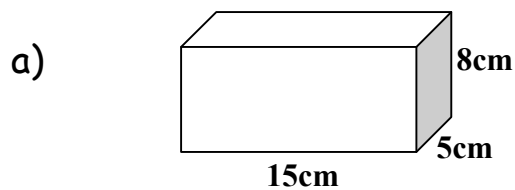

3. A plan of Wilfred's garden is shown below. It is grass except for the flower bed shown (which is symmetrical).

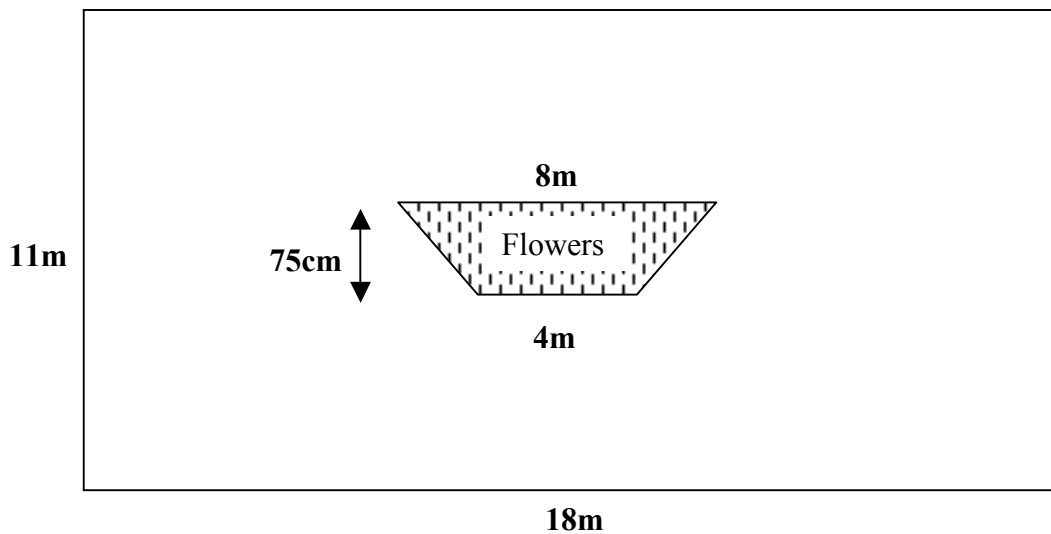

Wilfred (who obviously has far too much time on his hands) estimates that there are 20 ants for each square metre of grass.
Use his estimate to calculate the amount of ants in his lawn.

4. The design for some new comfy chairs is shown here.

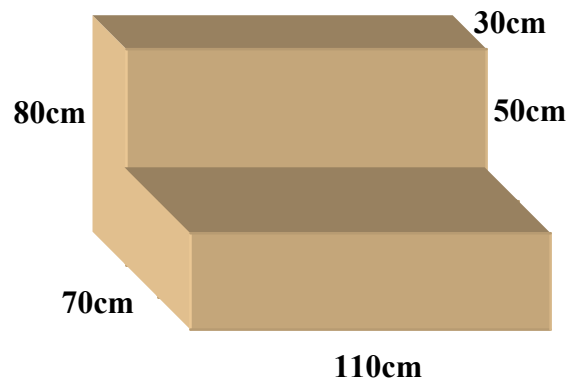

- a) Calculate the volume of each chair.

The chairs are to be made of foam which is initially produced as a liquid.

- b) How many chairs can be produced from 3 000 litres of foam?

Level 3 Groundwork Homework
Angle Symmetry and Transformation 2

1. Pupils from Yontoon High School are going to the theatre.



The layout of the seats in the theatre are shown below:



<u>Row</u>	<u>Seat Number</u>							
A	1	2	3	4	5	6	7	8
B	1	2	3	4	5	6	7	8
C	1	2	3	4	5	6	7	8
D	1	2	3	4	5	6	7	8
E	1	2	3	4	5	6	7	8
F	1	2	3	4	5	6	7	8

Pupils' tickets are as follows:

Paul	C5	Sadiq	D4	Jeremy	C4
Denise	E4	Barbara	D5	Theresa	D3
Sammy	E3	Gertrude	C3	Darren	E5

- a) Who will be sitting behind Paul?
b) Who will be sitting in front of Theresa?
c) Who will be on Sadiq's right?
2. Draw a coordinates Grid and plot the following points:

A (3,5) B(7,2) C(0,6) D(3,0)

3. Identify the letters given by the coordinates to make words and find the hidden message.

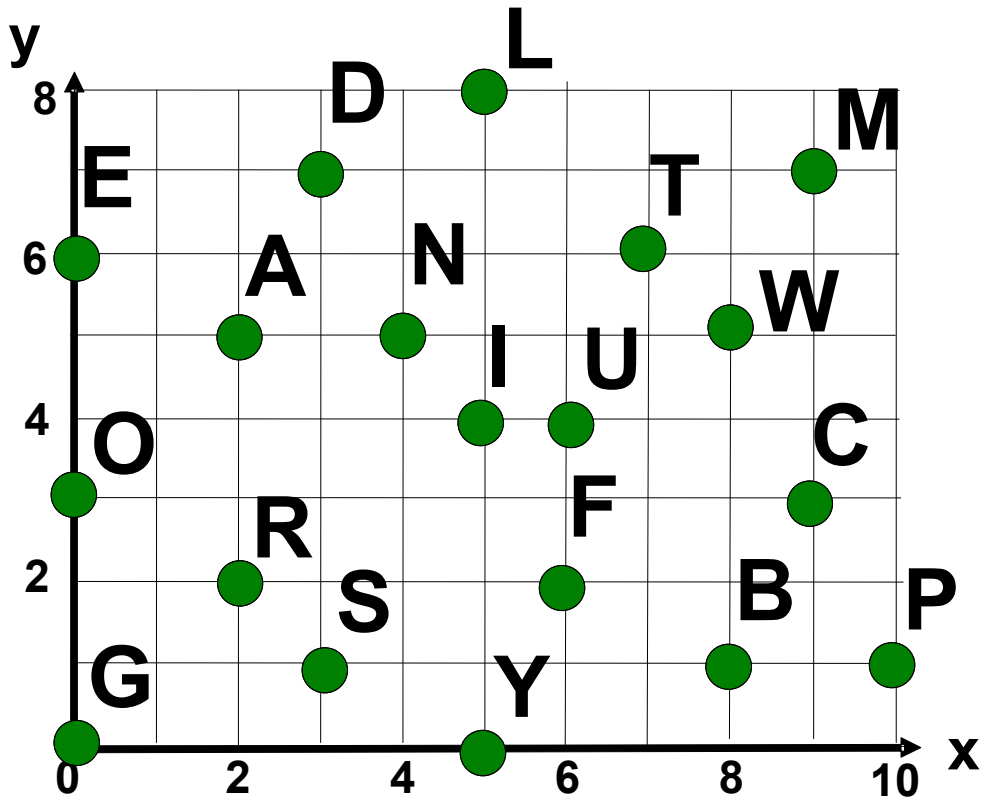

(8 , 5)	(0 , 6)	(5 , 8)	(5 , 8)	/
(3 , 7)	(0 , 3)	(4 , 5)	(0 , 6)	/
(5 , 0)	(0 , 3)	(6 , 4)	(4 , 5)	(0 , 0) /
(2 , 5)	(3 , 7)	(6 , 4)	(5 , 8)	(7 , 6)

4. A model sword is shown here.
The model is 8cm long.

The real sword is 10 times as big as the model.

Calculate the length of the real sword.

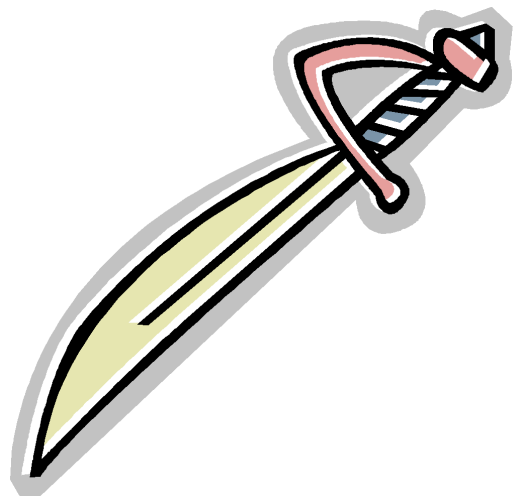

5. Here is a map of Cosma Island.

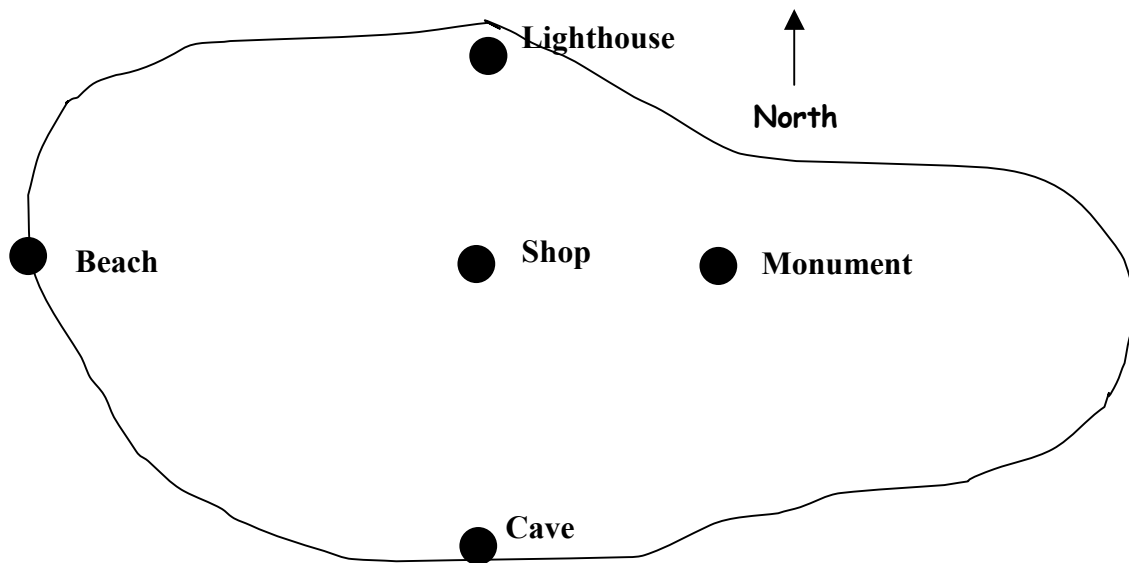

- a) What landmark is due south of the shop?
- b) What landmark is due west of the shop?
- c) Billy is walking from the monument to the lighthouse. What direction should he travel in?

6. Copy the shape below and draw an enlargement where each side is double the length.

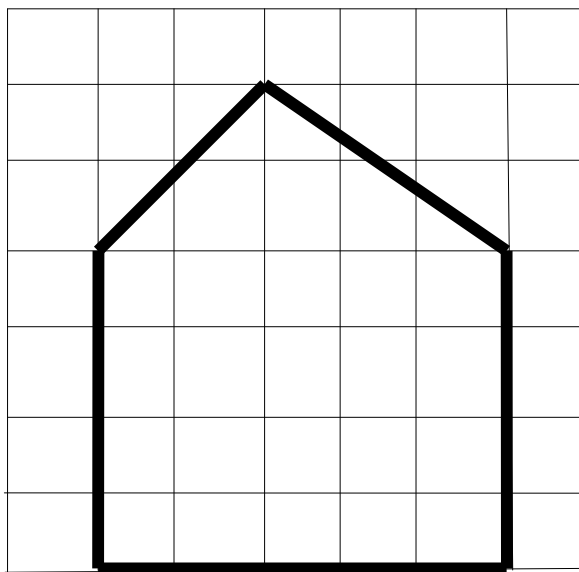

Level 3 Core Homework
Angles Transformation and Symmetry 2

1. Here is a map of the Isle of Lismerra.

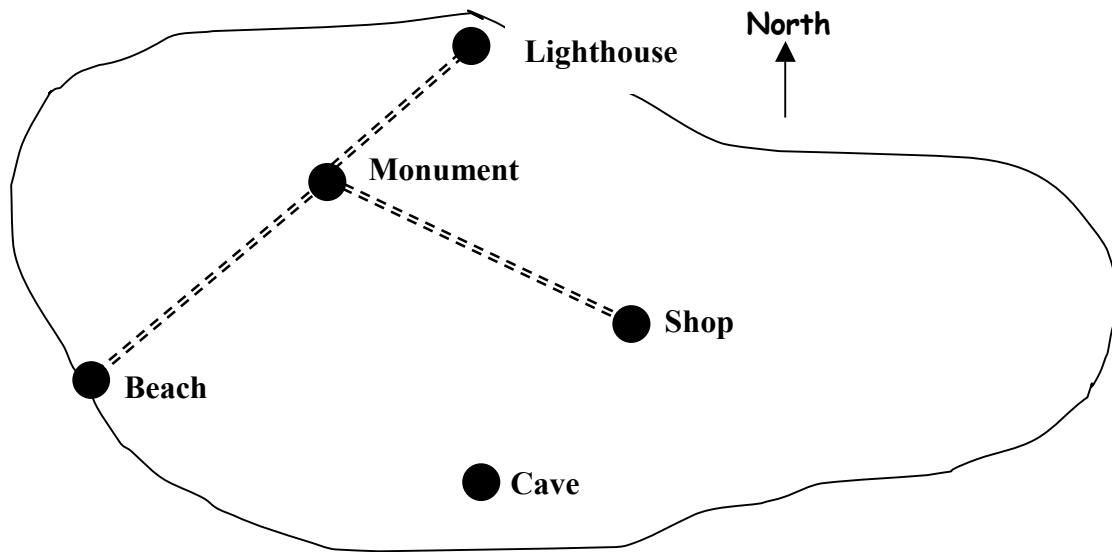

Scale 1cm = 2miles

Path =====

- a) What landmark is due south of the Lighthouse?
 - b)
 - i) What direction is the shop from the cave?
 - ii) Write this as a bearing.
 - c) Billy is walking from the beach to the monument. He meets Sheila who is walking in the opposite direction. What direction is Sheila heading in?
 - d) Use the scale to calculate the real length from the beach to the monument. (Show working)
2. a) Draw a coordinate grid and plot the following points:
- A(3 , 6) B(3 , 3) C(9 , 3)
- b) What is the y-coordinate of A?
 - c) ABCD is a rectangle.
Plot D on your grid and write down its coordinates.

3. a) Draw a scale drawing of the rectangular field below.
Use a scale of 1cm = 10m

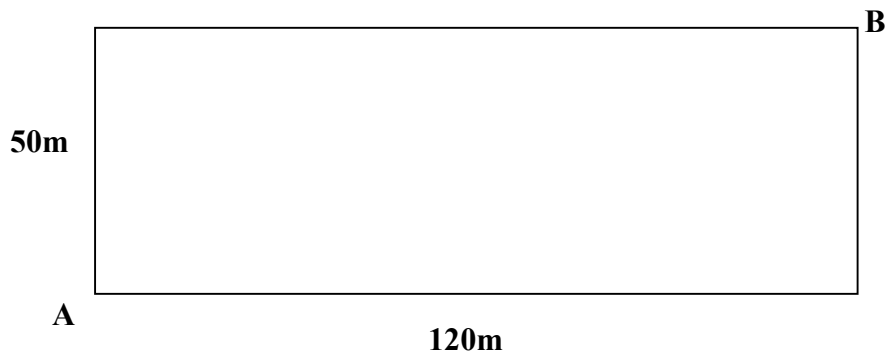

- b) Use your diagram to calculate the distance from corner A to corner B. (Working!)
4. Draw a reduction of the shape below using a scale factor of $\frac{1}{2}$.

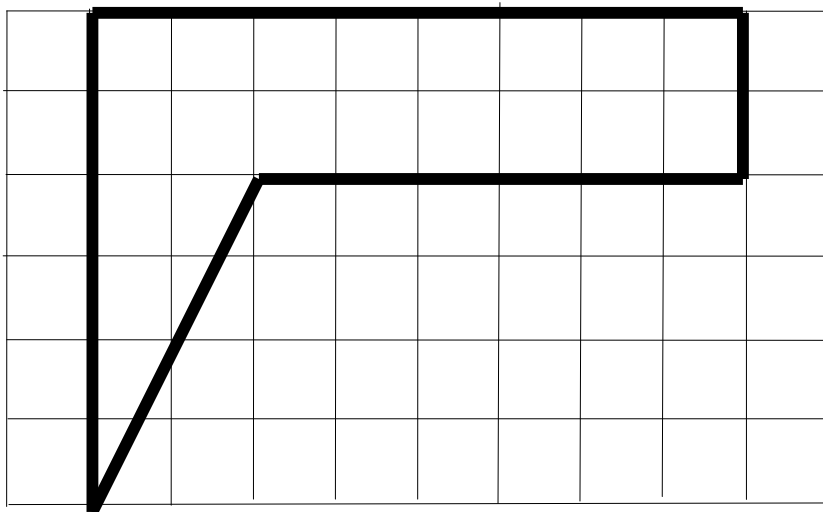

5. A model sword is shown here.
The model is 8cm long.

The real sword is 80cm long

Calculate the enlargement
scale factor

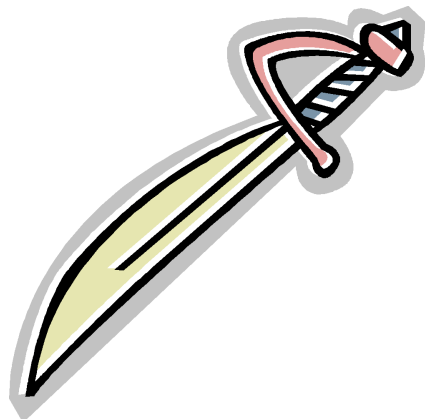

Level 3 Extension Homework
Angles Transformation and Symmetry 2

1. Write down the bearing of B from A.

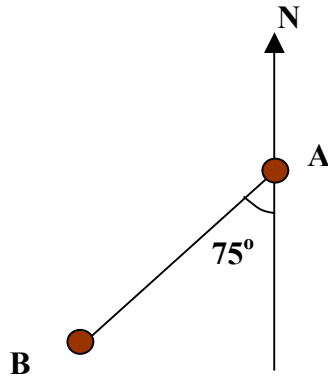

2. Here is a map of the Isle of Lismerra.

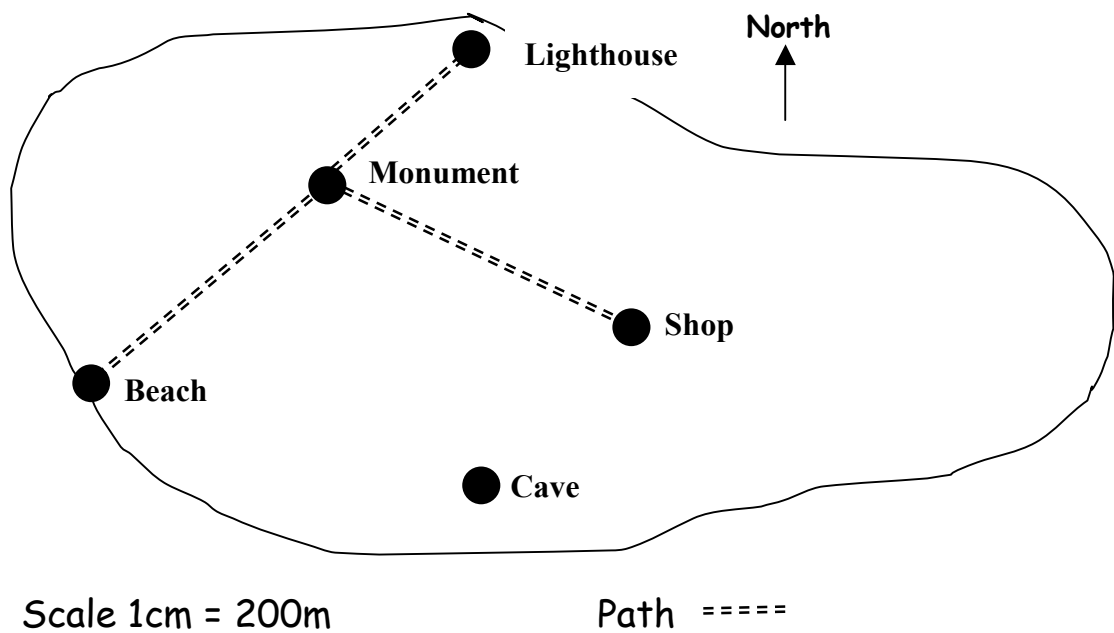

- a) What is the real distance from the lighthouse to the Monument. (Show working)
- b) i - What direction is the cave from the shop?
ii - Write this as a bearing

3. a) Draw a coordinate grid and plot the following points:

$A(3, -6)$ $B(3, 3)$ $C(-2, 3)$

b) What is the y-coordinate of A?

c) ABCD is a rectangle.

Plot D on your grid and write down its coordinates.

4. a) Construct a scale drawing of the side of the shed below.

Use a scale of $1\text{cm} = 50\text{cm}$

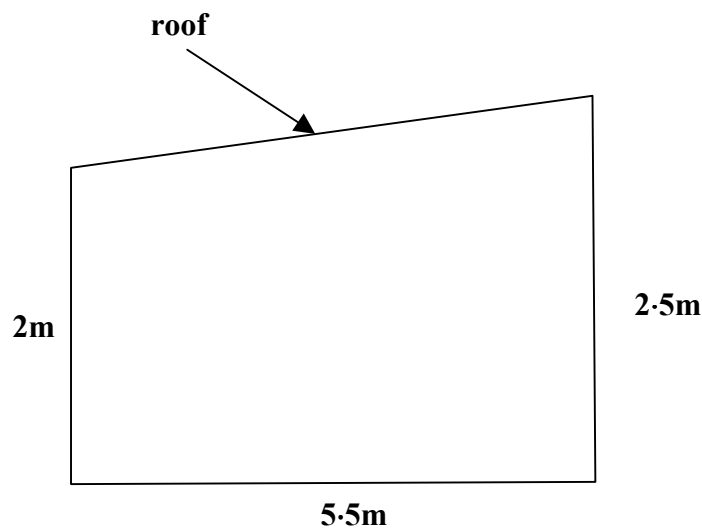

b) Use your diagram to calculate the real length of the roof.

(show working)

5. Draw a reduction of the shape below using the scale factor $\frac{1}{3}$.

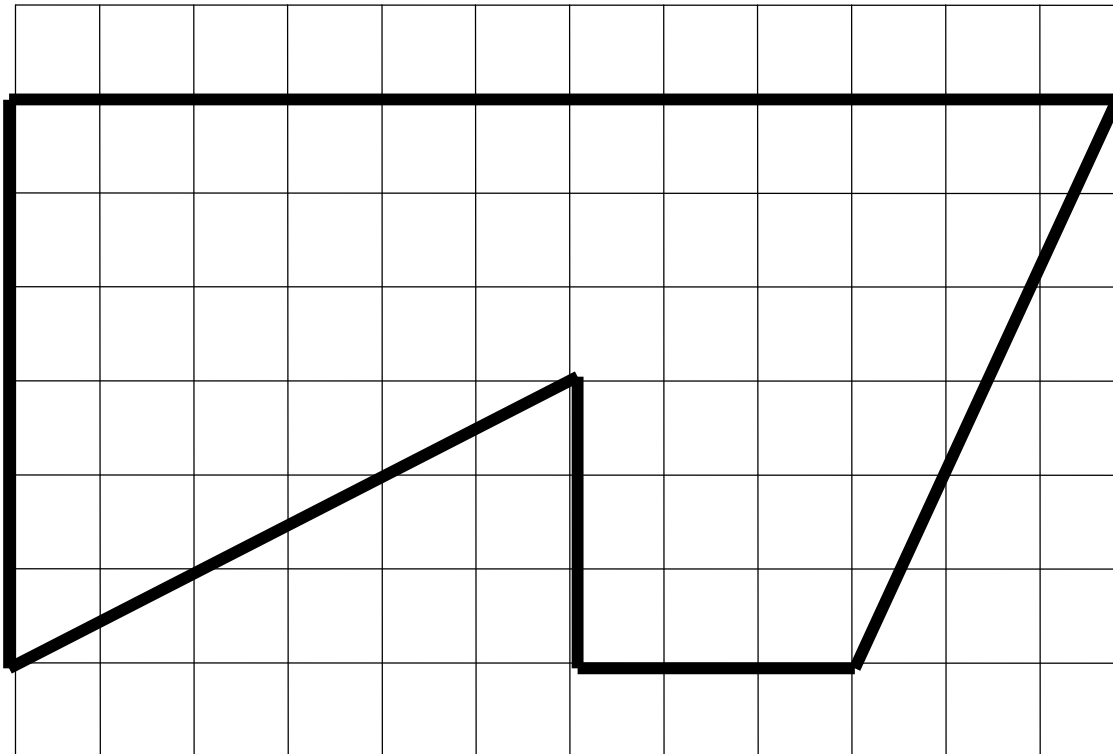

- 6 The diagrams show a model car and the real car with some of their measurements.

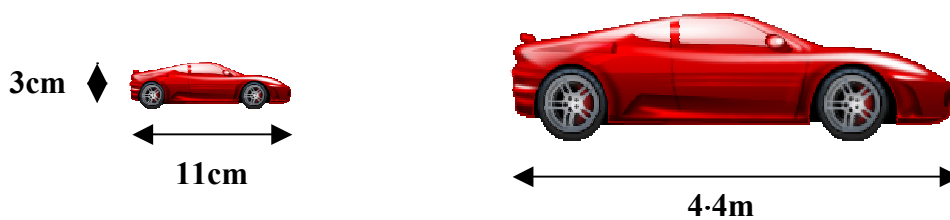

- a) Calculate the enlargement scale factor.
- b) Use the scale factor to calculate the height of the real car.

Level 3 Groundwork Homework
Money

1. Edgar is saving up to buy a bike.



He plans to save £6 per week.

- a) How much will he have saved after 20 weeks?
- b) The bike costs £330.
Will Edgar have saved enough money to buy it after a year?
(Give a reason for your answer)

2. Helga has £640 in her savings account.



The interest rate is 2% p.a.

How much interest will she get after one year?
(See memory jogger below for help with percentages)

Memory Jogger



Calculator Percentages

Steps to success



Change to decimal

Multiply

Put in units

(and extra zero if required)

$$\begin{aligned} &= 17\% \text{ of } \pounds 40 \\ &= 0.17 \times 40 \\ &= \pounds 6.80 \end{aligned}$$

3. Kenny is doing some home improvements and gets a loan of £2 000 from the bank.

He is to repay the loan with 24 payments of £95.



- a) What is the total cost of his repayments?
- b) How much extra has he had to pay the bank?

4. Stephanie is buying a TV using Hire Purchase.

She has to pay a deposit of £60, then 12 monthly payments of £35 each.



- a) How much will this cost her altogether?
- b) The cash price of the TV was £430.

How much extra has Stephanie had to pay by using Hire Purchase?

5. Basil is going to Paris.
He is taking £80 spending money.



- a) What currency will he need?
- b) Use the table below to calculate how much money he will get for his £80.

<u>Currency</u>	<u>Exchange Rate (per pound)</u>
Dollars	1.65
Euros	1.15
Yen	160
Kroner	8.70

Level 3 Core Homework
Money



1. Heidi is saving up to buy a bike.
The bike costs £286.
Her kind Auntie gives her £70 to help her.
If Heidi saves £9 per week, how long will it take her to save enough money for the bike?



2. Cedric has £640 in his savings account.
The interest rate is 2% p.a.
- a) How much interest will he get after one year?
- b) How much will he now have in his account once he has received his interest?
(Assume that he has not withdrawn any money)

3. Ushi takes out a loan of £4 000 to help her buy a car.



For a three year loan the cost of the interest will be £392.

How much will she have to pay each month?

4. Pedro is going to buy a Lap Top.
He has a choice of paying the Cash
Price shown or by paying by Hire
Purchase.



Cash Price £430

The terms for Hire Purchase are
Deposit: 10% of Cash price
Payments: 24 payments of £17

- a) How much would it cost to buy the Lap Top
using Hire Purchase?
b) Would you advise Pedro to pay by cash or Hire
Purchase?
(Give a reason for your answer)
5. Stella is going to New York
She is taking £90 spending money.



- a) Use the table below to calculate how
much she will receive for her money.
(Make sure you choose the correct currency)

<u>Currency</u>	<u>Exchange Rate (per pound)</u>
Dollars	1.65
Euros	1.15
Yen	160
Kroner	8.70

- b) While in New York she spends \$108.50.
She changes the rest back to pounds.
How much will she get back?
(Assume that the exchange rate has not changed.)

Level 3 Extension Homework
Money

1. Penny has £640 in her savings account.
The interest rate is 1.8% p.a.



- a) How much will she have in her account after a year once she has received her interest?
(Assume that she has not withdrawn any money)
- b) How much interest will she be due if she decides to withdraw her money after 3 months?

2. Karl takes out a loan of £3 000 to help him buy a car.
For a two year loan the total charge for interest will be 16%.



How much will she have to pay each month?

3. Lolita is going to buy furniture.
She has a choice of paying the Cash Price shown or by paying by Hire Purchase.

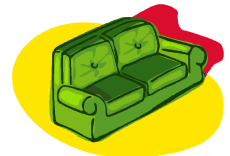

The terms for Hire Purchase are
Deposit: 10% of Cash price
Payments: 24 payments of £83.50

Cash Price £2000

Her bank can offer her a three year loan with an interest charge of 13%.

- a) Calculate the cost of paying by Hire Purchase
- b) Calculate the total cost of the loan and the price of each monthly payment.
- c) Write down at least one advantage and disadvantage of each method of payment.

4. Sammy is going to Rome.
He is taking £120 spending money.



- a) Calculate how much Sammy will get from the two options below.

Yon Bank	
<u>Currency</u>	<u>Exchange Rate (per pound)</u>
Euros	1.14

Dodgy Exchange	
<u>Currency</u>	<u>Exchange Rate (per pound)</u>
Euros	1.16
(+3% Handling Charge)	

- b) Sammy decides to change his money with Yon Bank.
When in Rome (as they say!) he spends €88.40.
He knows that you cannot change back coins so keeps as many notes as possible.

How much money will he get when he changes his money back to pounds if the exchange rate is now €1.13 per pound?

Level 3 Groundwork Homework
Properties of 2D Shapes and 3D Objects

1. An isosceles triangle is shown below:

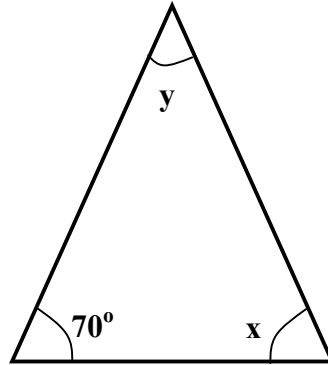

- a) What is special about an isosceles triangle.
b) What are the sizes of angles marked x and y?
2. Two equal isosceles triangles are fitted together to form a new shape as shown.

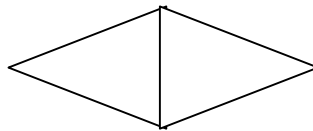

- a) What will be special about the new shape?
b) How many lines of symmetry will it have?
c) What is the name of this shape?
3. Which of the shapes shown below would **not** be suitable for a tiling?
Give a reason for your answer.

a)

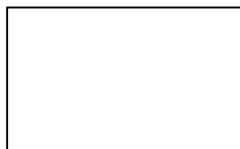

b)

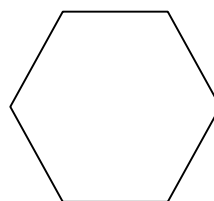

c)

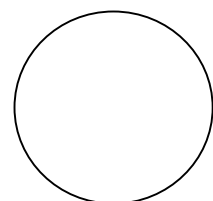

4.

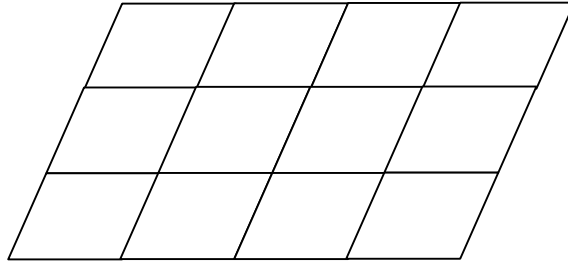

Part of a tiling is shown here.

- What shape has been used to make the tiling.
- Draw a tiling of your own using a different shape.
(You must use the shape at least six times)
- Write the name of the shape used in your tiling.

5. A box of cereal is shown here.



- What is the mathematical name for the shape of the box?
- Which of the nets shown below could be used to make a box like this?

X

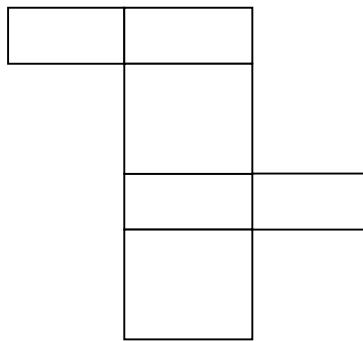

Y

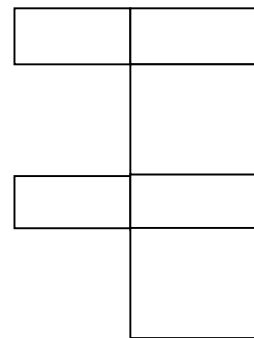

- Name something else that you can buy in this shape of box.
- Give at least one advantage of using boxes of this shape.

Level 3 Core Homework
Properties of 2D Shapes and 3D Objects

1. A kite is shown below:

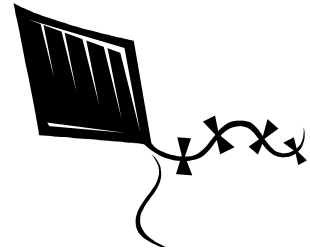
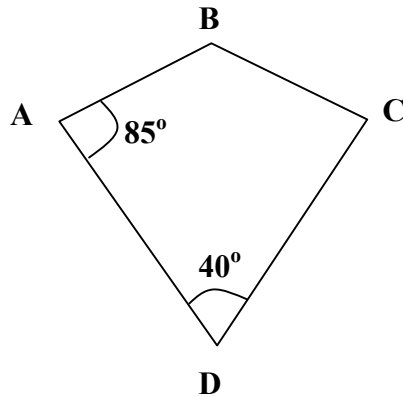

- a) What is the size of $\angle BCD$?
- b) Calculate the size of $\angle ABC$.
- c) The perimeter of the kite is 20cm.
If $BC = 3\text{cm}$, calculate the length of CD .
2. If two equilateral triangles are joined together (side to side) what shape will they form?
(A sketch may help)
3. Which of the shapes shown below would **not** be suitable for a tiling?
Give a reason for your answer.

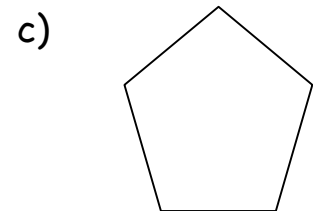
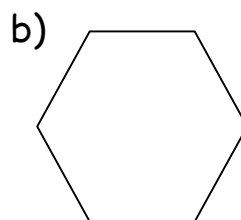
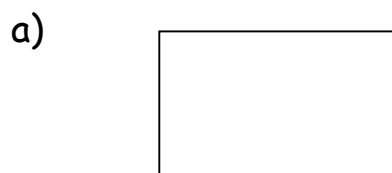

4. Draw a parallelogram tiling.
(You must use the shape at least six times)

5. A gift box for jewellery is to be made with the measurements shown.

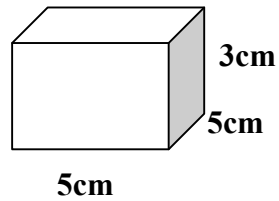

Draw an accurate net that would make a box with these dimensions.

6. a) Name at least five different items that are stored in cylinders. No more than one type of drink is allowed and name at least one item that should not be drunk or eaten.
- b) State at least two reasons why cylinders are so commonly used as containers.

Level 3 Extension Homework
Properties of 2D Shapes and 3D Objects

1. A kite is shown below:

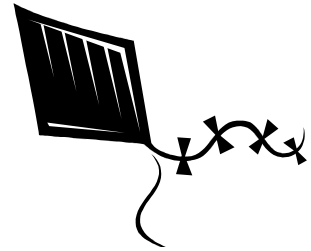
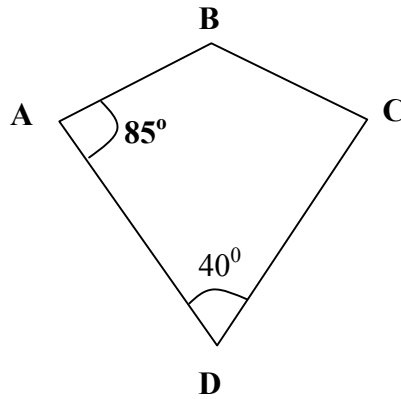

- Calculate the size of $\angle ABC$
- The perimeter of the kite is 24cm. If CD is twice the length of BC, find the length of each.

2. Six triangles have been joined together to form a regular hexagon as shown.

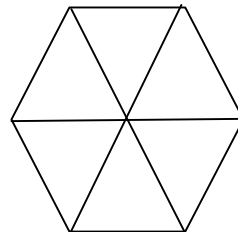

Pandora thinks that they would have to be equilateral triangles, while Pat says that isosceles triangles would do the job.

Who is correct?

You must support your answer with a clear reason.

3. The diagram shows a small parallelogram tiling.

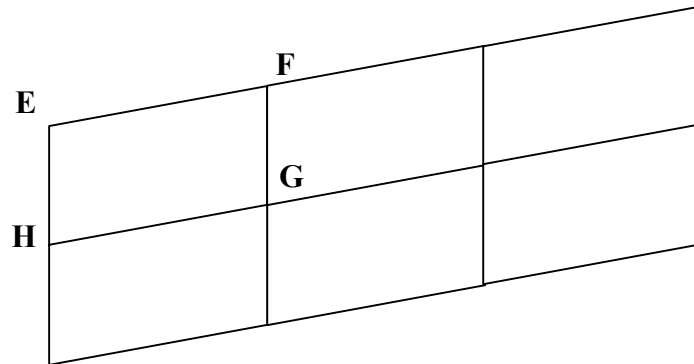

The perimeter of the tiling is 68cm.

If $EH = 5\text{cm}$, calculate the length of HG .
(Show your working)

4. A gift box for jewellery is to be made with the measurements shown.

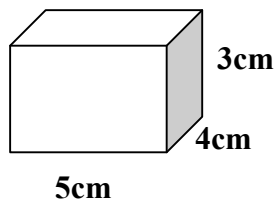

Draw an accurate net that would make a box with these dimensions.

5. A cube has a volume of 64cm^3 .
Calculate the total surface area of its net.
(Remember the working!)

Level 3 Groundwork Homework
Time

1. Tracy is told that her hockey match will start at quarter past two.



Write this time in figures.

Put a.m or p.m (which do you think it must be?)

2. Here is the TV guide for a Saturday morning:

8:30	The Mumbles
8:50	The Saturday Show
9:15	Film: Where is my brain?
10:55	The News
11:05	Sports Round Up

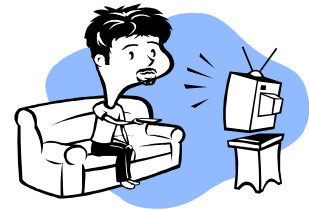

- a) How long does The Mumbles last?
- b) Which programme starts at five to eleven?
- c) Sylvester turned on the TV at half past nine.
i) Which programme was on?
ii) How much had he missed?
- d) How long does The Saturday Show last?
3. Marion drives a distance of 60 miles.
This takes her 2 hours.
What is her average speed in miles per hour?



4. The bus timetable from Glasgow to Dundee is shown below.



Glasgow	09 50	11 30	14 30
Stirling	10 30	12 10	15 10
Perth	11 22	13 02	16 06
Dundee	12 06	13 46	16 50

- a) The last bus leave Glasgow at 14 30.
What time does it arrive in Dundee?
- b) Write this in 12 hour clock time.
(Remember to put a.m. or p.m.)
- c) How long does it take to travel between Glasgow and Stirling?
- d) Omar needs to be in Dundee at 1 p.m.
He lives in Stirling.
What bus should he get?
5. Barry runs 16 miles in two hours.
What is his average speed in miles per hour?



Level 3 Core Homework
Time

1. The Television times for a Tuesday afternoon are shown.

11 40	Wee Brother
12 15	Film - It Can Only Get Worse
13 45	The News
14 10	Afternoon Madness
14 35	Cartoon Special
16 10	The Horrific Gameshow

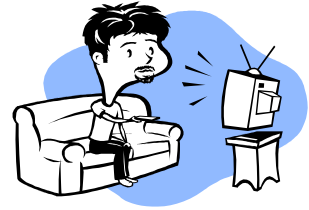

- a) How long does the news last?
- b) Write the starting time for *Afternoon madness* using 12-hour time.
- c) If you turn on the TV at quarter to four, what will be on?
- d) How long does *Cartoon Special* last?

2. The bus timetable from *Glasgow* to *Dundee* is shown below.

Glasgow	09 44	11 28	14 32
Stirling	10 20	12 04	15 08
Perth	11 18	13 02	16 06
Dundee	12 02	13 46	16 50



- a)
 - i) - What time does the last bus leave *Glasgow*?
 - ii) - Write this in 12 hour- time.
- b) How long does the first bus take to travel between *Glasgow* and *Stirling*?
- c) *Edna* is waiting at the bus stop in *Perth* at quarter to one in the afternoon.
 - i) - How long will she have to wait until the bus arrives?
 - ii) - When will she arrive in *Dundee*?

3. Calculate the average speeds of the following, taking care to write the calculation and the correct units.

a) Sandra drives 90 miles in 2 hours.



b) Brendan jogs 24 metres in 8 seconds.



4. Calculate how far was travelled in each of these cases.
(Calculation and units required)

a) Elena drove for 3 hours at an average speed of 40 mph.



b) Gary the greyhound ran at an average speed of 18 metres per second for 10 seconds.

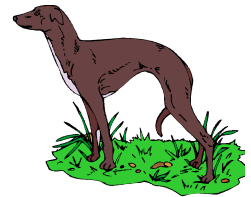

5. Now calculate how much time each of these took.
(Calculation and units still required)

a) Homer drove 300 miles at an average speed of 50 mph.



b) Tasia walked 20 km at an average speed of 4 km per hour.



Level 3 Extension Homework
Time

1. Calculate the average speeds of the following, taking care to write the calculation and the correct units.
 - a) Sandra drives 90 miles in 2 hours.
 - b) Brendan jogs 24 metres in 8 seconds.
 - c) Sammy the Slug crawls 10cm in $2\frac{1}{2}$ hours.

2. Calculate how far was travelled in each of these cases.
(Calculation and units required)
 - a) Elena drove for 3 hours at an average speed of 40 mph.
 - b) Gary the greyhound ran at an average speed of 18 metres per second for 10 seconds.
 - c) Cedric walked for $6\frac{1}{4}$ hours at an average speed of 4 kilometres per hour.

3. Now calculate how much time each of these took.
(Calculation and units still required)
 - a) Homer drove 300 miles at an average speed of 50 mph.
 - b) Tasia ran 100 metres at an average speed of 5 metres per second.
 - c) Tony the Tortoise travelled 10 metres at an average speed of 4 metres per minute.

4.



The Easter Bunny took one hour 30 minutes to deliver his eggs. If he travelled 225 miles altogether, calculate his average speed.

5. Sid drove at an average speed of 40 mph for 100 miles.
How long did this take him?
(Give answer in hours and minutes)

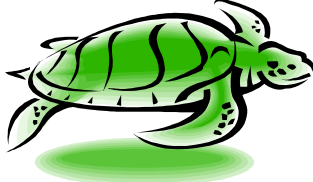

6. 

Thomas the Turtle has been swimming for 2 hours 15 mins. His average speed is 4 km/h.
How far has he swum?

7. The train timetable from Glasgow to Oban is shown below.
If the train travels an average speed of 50 mph between Dumbarton and Oban, calculate the distance between the two towns.



	08:50	13:30
Dumbarton	09:10	13:50
Crianlarich	10:00	14:40
Taynuilt	10:25	15:05
Oban	10:40	15:20

8. Anita leaves home at 08:45.
She is driving to a meeting 108 miles away.
She wants to arrive at 11:00.
If she is to arrive exactly on time, at what average speed will she have to drive?



Level 3 Groundwork Homework

Mixture

1. Write down the next two numbers in each of these sequences:

a) 3, 6, 9, 12, 15.....

b) 81, 79, 77, 75, 73.....

c) 3, 9, 15, 21, 27.....

d) 1, 2, 4, 8, 16.....

2. Ruth the restaurant owner is considering the number of tables she will need to seat her customers.

She draws up some plans which are shown below.

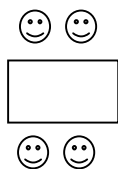

1 Table

4 customers

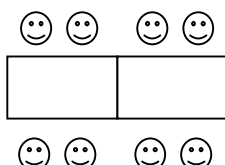

2 Tables

8 customers

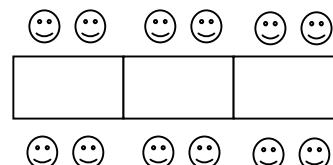

3 Tables

12 customers

a) Copy the table below and fill in the blank spaces.

Tables(T)	1	2	3	4		8
Customers(C)	4	8	12			

b) Find the missing number to give you a rule.

Customers = × Tables

c) Use your rule to calculate how many customers you would have round 10 tables.

3. The diagram shows all the different pairs on numbers you can multiply to make 12.

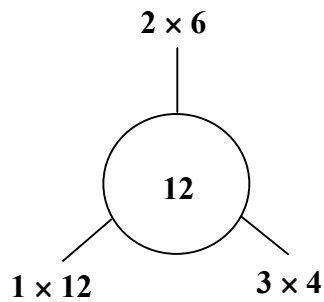

- a) Copy and complete this diagram doing the same for 20.

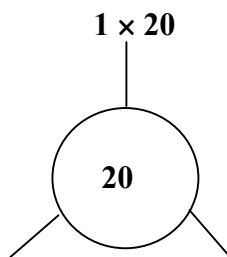

From the top diagram, we can say that the **factors** of 12 are 1, 2, 3, 4, 6, 12.

- b) Use your diagram to write down the factors of 20.
 c) What are the factors of 15?
4. Ivan has 12 marbles.

He sets them out in three rows of four as shown:

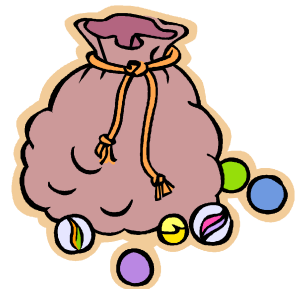

- a) Write down what other arrangement he could use to give him a rectangular shape like this.
- b) Ivan loses one of his marbles.
 Explain why he will not be able to use all of his marbles to make a rectangular shape.

5. Name a famous mathematician and write down something that he/she is known for.



OR

Write a few sentences on a mathematical topic that you know about.



6. Molly is on a TV game show.
She is playing "Higher or Lower"
The spinner points to a number from 1 to 12.
She must then choose whether the next number will be higher or lower.
(It is possible for the spinner to point to the same number again)



The number is pointing to 6.

Should Molly choose higher or lower?
Explain your answer.

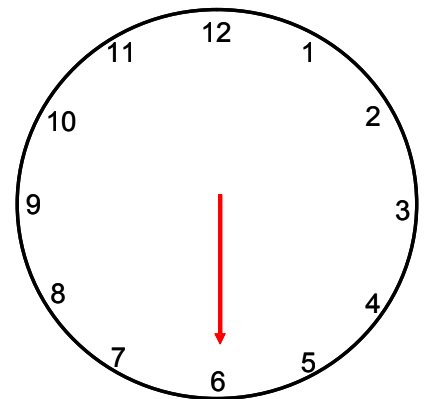

Level 3 Core Homework

Mixture

1. Write down the next two numbers in each of these sequences:

a) 1, 5, 9, 13, 17.....

b) 55, 49, 43, 37, 31.....

c) 1, 2, 4, 8, 16.....

d) 1, 2, 4, 7, 11.....

2. Ruth the restaurant owner is considering the number of tables she will need to seat her customers.

She draws up some plans which are shown below.

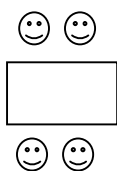

1 Table

4 customers

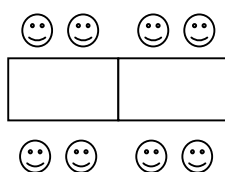

2 Tables

8 customers

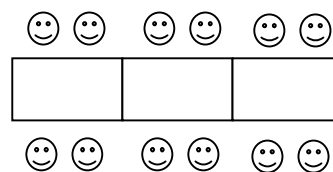

3 Tables

12 customers

a) Copy the table below and fill in the blank spaces.

Tables(T)	1	2	3	4		8
Customers(C)	4	8	12			

b) Find a rule that allows you to calculate the number of customers if you are told the amount of tables. Write it in form $C =$ (where C is the number of Customers)

c) Use your rule to calculate how many customers you would have round 15 tables.

3. a) Write down all the factors of the following numbers:

i) 8

ii) 18

iii) 9

b) Find all prime numbers that are between 10 and 20.

4. Ivan has 24 marbles.
He sets them out in four rows of six as shown:

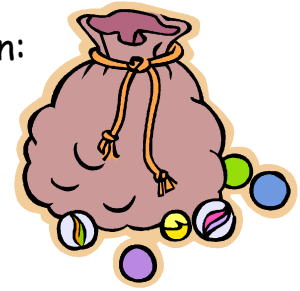
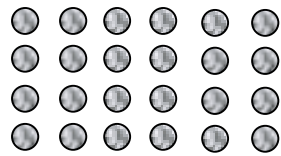

- a) Write down what other arrangements would give a rectangular shape like this.
- b) Ivan loses one of his marbles.
Explain why he will not be able to use all of his marbles to make a rectangular shape.

5. Name a famous mathematician and write down something that he/she is known for.



OR

Write a few sentences on a mathematical topic that you know about.

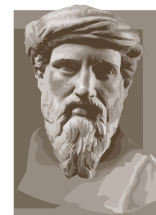

6. Molly is on a TV game show.
To find how much money she has won she must play "Heads or Tails"
A coin is flipped and she must choose heads or tails.
Molly chooses tails.



- a) What is the probability of Molly being correct?

It is tails, so Molly wins £10 000.

She now has the choice of playing "Heads or Tails" again playing "Pick a Card", or keeping her money.

To win in "Pick a Card", there are 10 cards with six marked as winners. If you pick a card marked winner you win (strangely enough!)

If Molly loses at "Heads or Tails" or "Pick a card" she will lose all of her money.

- b) What advice would you give Molly?
You must give a reason for your answer.

Level 3 Extension Homework

Mixture

1. Write down the next two numbers in each of these sequences:

- a) 1, 4, 8, 13, 19..... b) 25, 23, 19, 13, 5.....
 c) 48, 24, 12, 6, 3 d) 3, 8, 6, 11, 9.....

2. Ruth the restaurant owner is considering the number of tables she will need to seat her customers. She draws up some plans which are shown below.

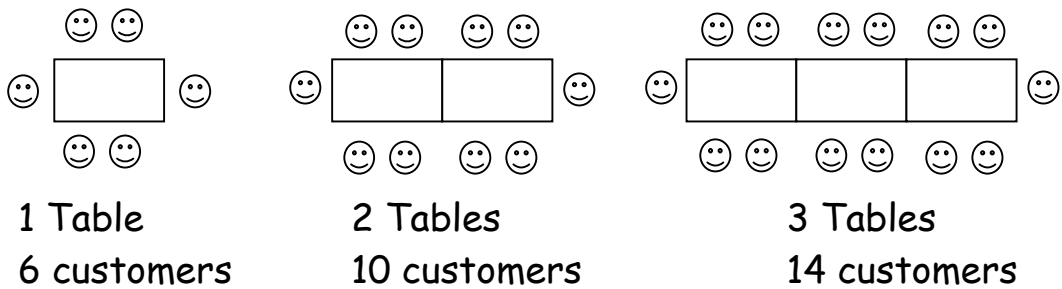

- a) Copy the table below and fill in the blank spaces.

Tables(T)	1	2	3	4		8
Customers(C)	6	10	14			

- b) Find a rule that allows you to calculate the number of customers if you are told the amount of tables. Write it in form $C =$ (where C is the number of Customers)
- c) Use your rule to calculate how many customers you would have round 15 tables.

3. a) Write down all the factors of the following numbers:
i) 18 ii) 24 iii) 25
- b) Find all prime numbers that are between 40 and 50.

4. Kilbarton pipe band has 36 members.
They usually march in eighteen rows of two pipers but are discussing the different formations they could have.
They agree that all rows must have the same amount of pipers and they will not march in single file or in just one row.



Write down all the possible formations they could march in.

5. Disaster strikes Kilbarton pipe band.
Just before they are due to play at the Kilbarton highland games a lot of the pipers come down with flu.
They are aware that some numbers of fit pipers would mean that they could not march in a suitable formation.



Write down all the numbers (less than 36) that would be unsuitable for marching in formation.

6. Molly is on a TV game show.
To find how much money she has won she must play "Higher or Lower"
The electronic spinner revolves before pointing to a number from 1 to 12.
She must then choose whether the next number will be higher or lower.
(It is possible for the spinner to point to the same number again)



After the first spin the number points to 3.
Molly chooses higher.

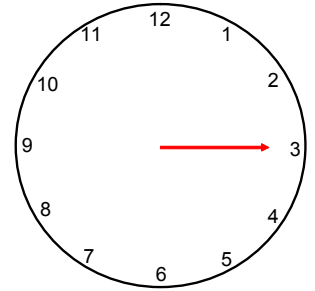

- a) What is the probability of Molly being correct?

The spinner points to 6, so Molly wins £10 000.
She can now keep her money or choose Higher or Lower again to double her money.
If she is wrong she will lose all her money.

- b) Which is more likely? Higher or Lower.
You must support your answer with working.
- c) What advice would you give Molly.
Give a reason for your answer.

7. Name a famous mathematician and write down something that he/she is known for.



OR

Write a few sentences on a mathematical topic that you know about.



Answers

Number Processes Groundwork

- a) Three thousand b) Two thousand four hundred and thirty-seven
c) Eight thousand and forty-six
- a) 8000 b) 4346 c) 2038
- a) 968 b) 897 c) 342
d) 128 e) 162 f) 69
- a) £477 b) 98p (c) 341 miles
- a) 740 b) 3420
c) 9 d) 53
- Tuesday is warmer at -2°C
- a) 5 b) 8 c) 13
- a) 70 b) 90 c) 240
- a) 500 b) 200 c) 3500

Number Processes Core

- a) One hundred and twenty-five thousand
b) Two hundred and thirty-five thousand six hundred and seventy-eight
c) Two hundred and four thousand and thirty-eight
- a) 235 000 b) 411 605
- a) 9696 (b) 1876
- a) 680 b) 224
c) 174 d) 8
- a) 603386 b) 27 c) £273
- a) 45300 b) 1234
- Chirnside Prague Helsinki Oslo
 2°C 0°C -4°C -8°C
- -2°C 9. $-\text{£}5$
- a) 5.7 b) 12.5 c) 24.9 d) 17.4

Number Processes Extension

1. a) Eight million, one hundred and twenty-five thousand
 b) Three million, two hundred and thirty-five thousand, six hundred and seventy-eight
 c) Nine million, four thousand and thirty-eight
2. a) 4637000 b) 6025605
3. a) 2220 b) 576 c) 632 d) 9
 e) 47000 f) 68000
4. a) 58855 miles b) 12 miles per litre.
 c) £448 d) 78 adults
5. -9°C
6. a) 7 b) -7 c) -63
 d) -5 e) -17 f) -101
7. a) 12.4 b) 20.0
8. a) 12.36 b) 19.40

Data Handling Groundwork

1. a)

Colour	Tally	Frequency
Red		8
Blue		7
Black		3
Green		5
Silver		7

b)

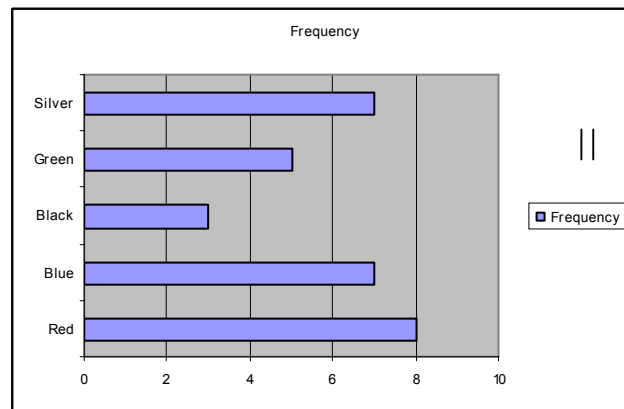

- c) RED is most popular colour of car.
2. The vertical axis has an irregular scale!
3. a) 18 b) 9
 c) No.
 e.g. Would expect city and rural results to be different.
 Some areas will not have any trains. etc.
4. a) 60
 b) Lower because dominoes players are probably less fit than athletes.

(For questions 3 and 4 accept any well argued point of view)

Fractions, Decimals and Percentages Groundwork

- $\frac{2}{5}$
- a) 9 b) 5 c) 5
- 18
- a) $\frac{1}{2}$ b) $\frac{1}{4}$ c) $\frac{27}{100}$
- a) 0.43 b) 0.3 c) 0.03
- a) 0.57 b) 0.02 c) 0.6
- a) 35 b) 10 c) 7
- £6
- a) 49 b) 133 c) 26
- 1624
- 780
- 210 miles

Fractions, Decimals and Percentages Core

- $\frac{2}{3}$
- a) $\frac{2}{7}$ b) $\frac{2}{3}$ c) $\frac{3}{4}$
- $\frac{4}{10}$ and $\frac{2}{5}$
- a) 4 b) 16 c) 27
- 6
- a) 0.7 b) 0.03 c) 0.15 d) 0.875
- a) 36% b) 90% c) 70% d) 62.5%
- a) $\frac{17}{100}$ b) $\frac{9}{20}$ c) $\frac{27}{100}$ d) $\frac{19}{50}$
- a) 21 b) 21 c) 10.5
- £2558.40
- a) 49 b) 133 c) 26
- 1624
- a) 81 b) 810
- a) 38 m.p.g. b) 418 miles

Fractions, Decimals and Percentages Extension

- $\frac{3}{5}$ $\frac{6}{10}$ $\frac{120}{200}$ etc.
- a) $\frac{11}{3}$ b) $\frac{38}{7}$
- a) $1\frac{5}{9}$ b) $4\frac{4}{5}$
- a) $\frac{7}{8}$ b) $\frac{3}{10}$ c) $\frac{19}{12}$ ($1\frac{7}{12}$)
- a) 0.62 b) 0.05 c) 0.13
- a) 71.9% b) 17.4% c) 4.2%
- a) $\frac{7}{50}$ b) $\frac{7}{200}$ c) $\frac{1}{25}$ d) $\frac{1}{400}$
- a) 28 b) 12.8 c) 14
- a) £5.12 b) £0.29 c) £0.12
- €236.19
- £11.27
- a) 2.1 litres of stock 525g mixed veg.
b) 30 minutes (not proportional)

Angles, Symmetry and Transformation 1 Groundwork

1. (a) 180° – Straight (b) 78° – Acute
 (c) 143° – Obtuse (d) 90° – Right
2. (a) $\angle ADH$ or $\angle HDA$ – *Acute*
 (b) $\angle GPC$ or $\angle CPG$ – *Right Angle*
 (c) $\angle BYD$ or $\angle DYB$ – *Obtuse*
3. (a) Actual angle is $\sim 28^\circ$ – accept 20° to 40°
 (b) Actual angle is $\sim 78^\circ$ – accept 65° to 85°
4. Personal judgement for sketches of (a) 100° angle and (b) 170° angle

5.

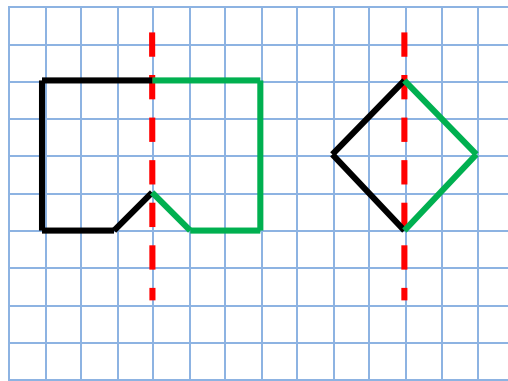

6.

(a)

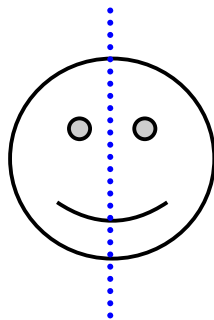

(b)

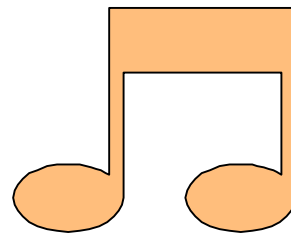

No Line of symmetry

(c)

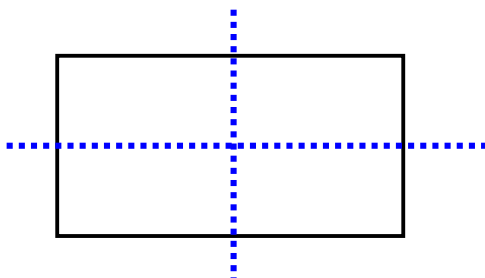

(d)

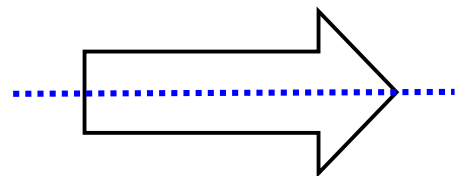

Angles, Symmetry and Transformation 1 Core

1. (a) $\angle DAB$ or $\angle BAD$ – Reflex
 (b) $\angle ABC$ or $\angle CBA$ – Acute
 (c) $\angle BCD$ or $\angle DCB$ – Obtuse
2. 25° 3. 132°
4. $\angle MKJ = 180 - 75^\circ = 105^\circ$ $\angle PKR = 105^\circ$ (Opposite $\angle MKJ$)
 $\angle JKR = 75^\circ$ (Opposite $\angle MKP$)
5. a) Missing angle = 40° b) Missing angle = 85°
- 6.

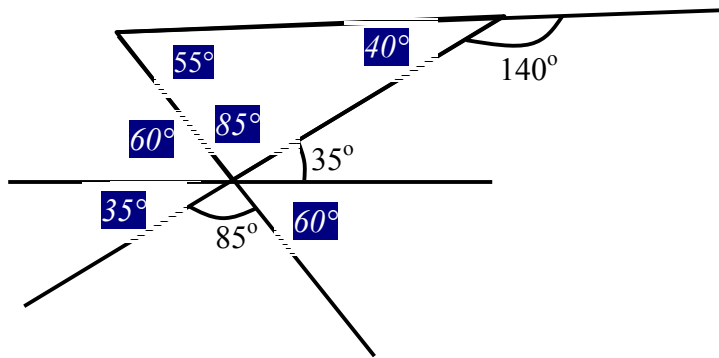

7.

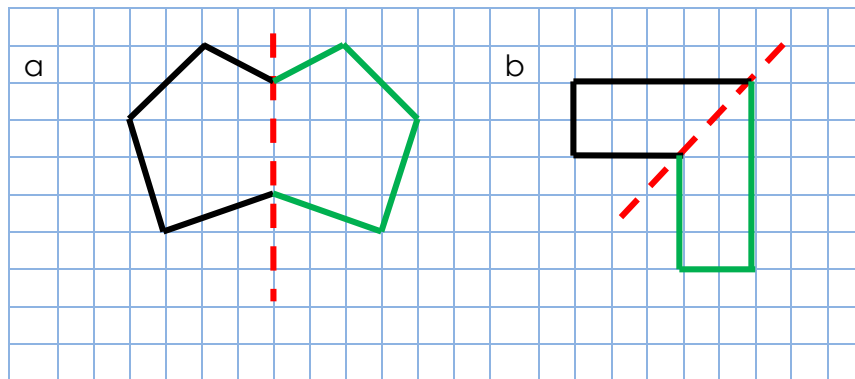

8.

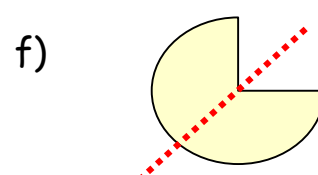
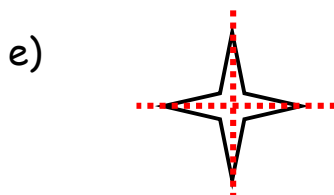
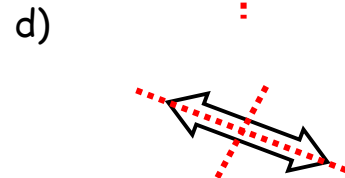
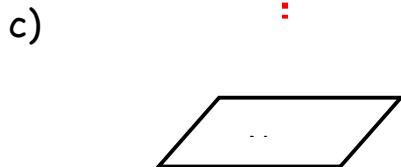
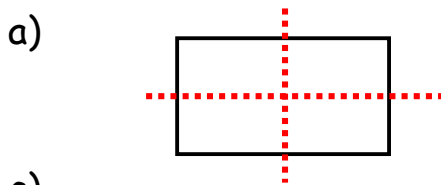

Angles, Symmetry and Transformation 1 Extension

1. (a) $\angle DAB$ or $\angle BAD$ – Reflex
 (b) $\angle ABC$ or $\angle CBA$ – Acute
 (c) $\angle BCD$ or $\angle DCB$ – Obtuse
2. $\angle MKJ = 180 - 75^\circ = 105^\circ$ $\angle PKR = 105^\circ$ (Opposite $\angle MKJ$)
 $\angle JKR = 75^\circ$ (Opposite $\angle MKP$)
3. (a) Missing angles are the same and $= 76^\circ$
 (b) Acute missing angles $= 126^\circ$ Obtuse missing angle $= 54^\circ$
4. a)

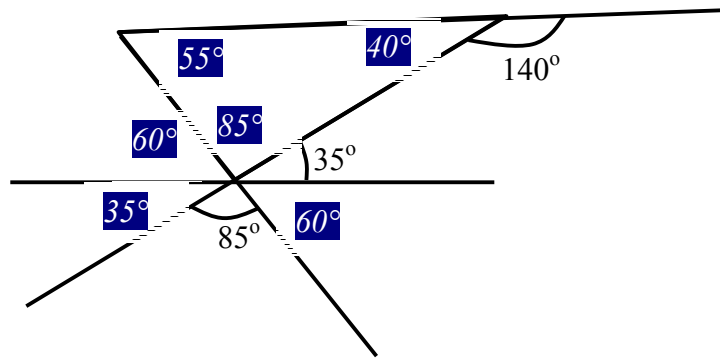

b)

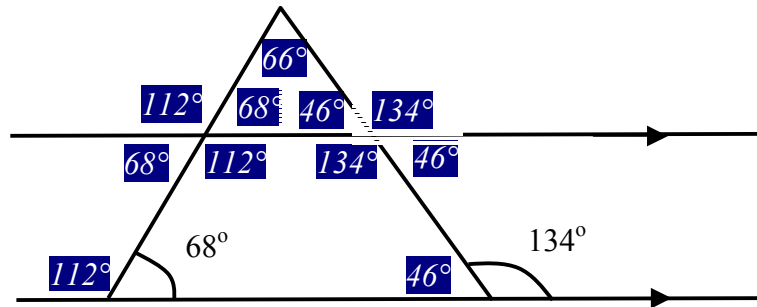

5. 67.5°
6. $a = 60^\circ$ $b = 30^\circ$
- 7.

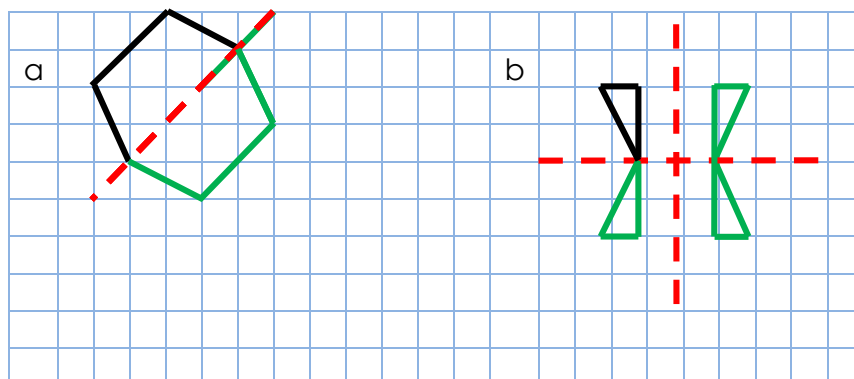

8. Any shape with 3 lines of symmetry e.g.

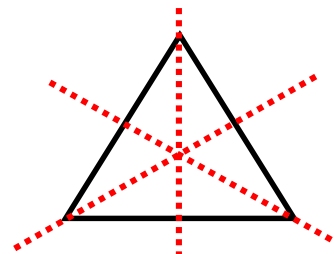

Expressions and Equations Groundwork

- a) $5a$ b) $10b$ c) $11d$
d) $5t$ e) $6y$ f) $7r + 6b$
- a) $2a + 4b$ b) $2b + 4p$
- a) 15 b) 1 c) 7
- a) $h = 8$ b) $w = 15$
c) $n = 9$ d) $s = 13$
- $b + 3 = 8$; $b = 5$
- a) $p = 2$ b) $y = 4$ c) $f = 7$ d) $t = 3$

Expressions and Equations Core

- a) $r + 3$ b) $2f + 1$
- a) $h + 5$ b) $h + 2$
- a) $r + 6$ b) $k - 2$
c) $t + 7$ d) $f + 2$
- a) $h + 1 = 8$; $h = 7$ b) $2n = 6$; $n = 3$
- a) $t = 11$ b) $t = 6$
c) $t = 5$ d) $a = 5$
- a) 9 b) 15 c) 6 d) 7
- a) $L = 4c$ b) $m = 60h$ c) $w = d \div 7$
- a) $G = 35$ b) $G = 16$ c) $G = 4$ d) $G = 31$

Expressions and Equations Extension

- a) $2f + 1$ b) $3t - 200$
- a) $2h$ b) $2h - 3$ c) $2h - 8$
- a) $5r$ b) $k - 4$
c) $3t + 12$ or $3(t + 4)$ d) $2f - 4$
- a) $m - 4$ b) $2r - 5$
- a) i) $4x = 80 - 20$ ii) $x = 15$
b) i) $66 + 8x = 146$; $x = 10$ ii) 40cm
- a) $t = 5$ b) $a = 5$
c) $y = 8$ d) $g = 40$
- a) 45 b) 8 c) 6 d) 18
- a) $F = 2C + 30$ b) $B = 20h + 30$ c) $W = 100 - 4d$
- a) $G = 62$ b) $G = 16$
c) $G = 4$ d) $G = 60$

Measurement Groundwork

1. a) 67km b) 7mm c) 12cm
d) 110m e) 4m
2. a) 15cm^2 b) 24cm^2
3. a) 7cm^2 b) 9cm^2
4. a) 7m^2 b) 70m^2
5. a) 30cm^3 b) 81cm^3
6. a) 250ml b) 60L
7. 3m^3

Measurement Core

1. a) 36cm^2 b) 28cm^2
2. a) 41cm^2 b) 52cm^2
3. a) 80cm^3 b) 64cm^3
4. a) 140m^2 b) £21
5. a) 4.8L b) 3.6L

Measurement Extension

1. a) 54cm^2 b) 66cm^2
c) 63cm^2 d) 85cm^2
2. a) 0.6L b) 8L
3. 3870 ants
4. a) 396000cm^3 b) 7 chairs

Angle Symmetry and Transformation 2 Groundwork

1. a) Barbara b) Gertrude c) Barbara
2. A(3,5) B(7,2) C(0,6) D(3,0) plotted.
3. Well done young adult.
4. 80cm.
5. a) Cave b) Beach c) North West
- 6.

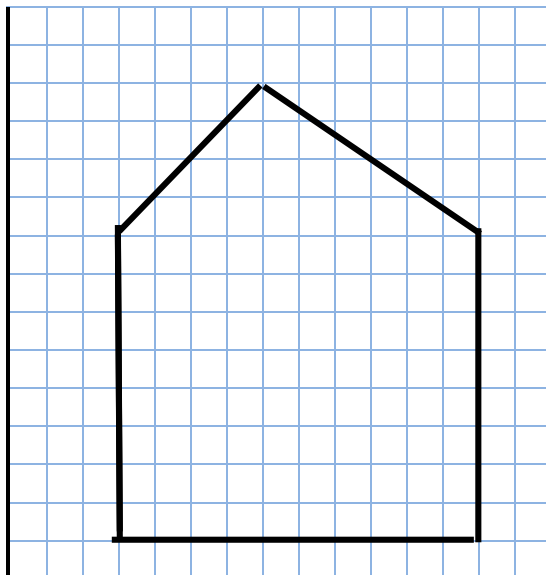

Money Groundwork

1. a) £120 b) Not enough, £18 short.
2. £12.80
3. a) £2280 b) £280
4. a) £480 b) £50
5. a) Euros b) €92

Money Core

1. 24 weeks.
2. a) £12.80 b) £652.80
3. £122
4. a) £451 b) Either answer with suitable reason.
5. a) \$148.50 b) £24.24

Money Extension

1. a) £651.52 b) £2.88
2. £145
3. a) £2204 b) Loan Cost £2260, monthly payment £62.78
c) e.g. HP - lower interest charge but need to pay deposit.
Loan – lower monthly payment, but higher interest charge.
4. a) Yon Bank - €136.80 Dodgy Exchange €135.02
b) $45 \div 1.13 = £39.82$

Properties of 2D Shapes and 3D Objects Groundwork

1. a) two sides and two angles are equal
b) $x = 70^\circ$ $y = 40^\circ$
2. a) All sides equal, opposite angles are equal.
b) Two lines. c) Rhombus
3. Part c) circle, it would leave gaps on the plane
4. a) Parallelogram b) Own tiling c) Correct name.
5. a) Cuboid b) X
c) Washing powder, Dog food etc.
d) They don't roll off the bench, easy to pick up one handed, easy to stack, easy to pour etc.

Time Groundwork

- 2:15 p.m.
- a) 20mins b) The News
c) i. Film – Where is my brain? ii. 15mins.
d) 25 mins.
- 30 m.p.h
- a) 16:50 b) 4:50 p.m.
c) 40 mins. d) First bus (10:30)
- 8 m.p.h.

Time Core

- a) 25mins b) 2:10 p.m.
c) Cartoon Special d) 1 hour 35 mins.
- a) i. 14:32 ii. 2:32 p.m.
b) 36 mins c) i. 17 mins ii. 13:46
- a) 45 m.p.h. b) 3 metres per sec.
- a) 120 miles b) 180m
- a) 6 hours b) 5 hours

Time Extension

- a) 45 m.p.h. b) 3 metres per sec c) 4 cm per hour
- a) 120 miles b) 180 m c) 25 km
- a) 6 hours b) 20 secs c) 2 mins 30 secs
- 150 m.p.h. 5. 2 hours 30 mins
- 9 km 7. 75 miles
- 48 m.p.h.

Mixture Groundwork

1. a) 18, 21 b) 71, 69 c) 33, 39 d) 32, 64
2. a) 16, 32 b) Customers = $4 \times$ Tables c) 40
3. a) $2 \times 10, 4 \times 5$ b) 1, 2, 4, 5, 10, 20
c) 1, 3, 5, 15
4. a) $2 \times 6, 4 \times 3, 6 \times 2$ b) 11, it is prime (or equivalent)
5. Suitable answer.
6. Higher; 6 chances compared to 5 (or equivalent)

Mixture Core

1. a) 21, 25 b) 25, 19 c) 32, 64 d) 16, 22
2. a) 16, 32 b) $C = 4 \times T$ c) 60
3. a) i. 1, 2, 4, 8 ii. 1, 2, 3, 6, 18 iii. 1, 3, 9
b) 11, 13, 17, 19
4. a) $2 \times 12, 3 \times 8, 6 \times 4, 8 \times 3, 12 \times 2$
b) 23 ; Prime (or equivalent)
5. Suitable answer.
6. a) Evens b) Pick a card or Keep Money with suitable reason.

Mixture Extension

1. a) 26, 34 b) -5, -17 c) $1\frac{1}{2}, \frac{3}{4}$ d) 14, 12
2. a) 18, 34 b) $C = 4T + 2$ c) 62
3. a) i. 1, 2, 3, 6, 9, 18 ii. 1, 2, 3, 4, 6, 8, 12, 24
iii. 1, 5, 25
b) 41, 43, 47
4. $2 \times 18, 3 \times 12, 4 \times 9, 6 \times 6, 9 \times 4, 12 \times 3$.
5. 31, 29, 23, 19, 17, 13, 11, 7, 5, 3, 2.
6. a) $\frac{9}{12}$ ($\frac{3}{4}$) b) Higher more likely; $\frac{6}{12}$ against $\frac{5}{12}$
7. Suitable answer.