



Lesmahagow High School
Mathematics Department

S2

Angles

Angles

1. Calculate the size of each lettered angle below:

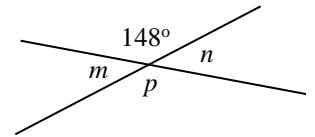
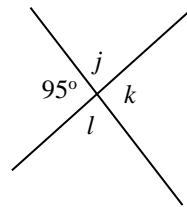
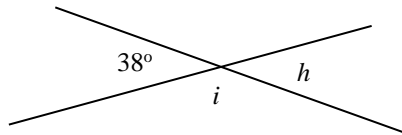
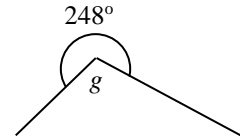
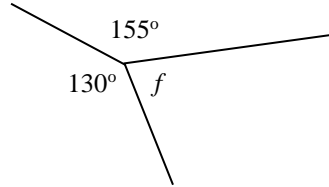
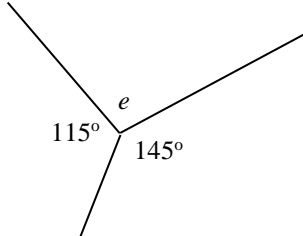
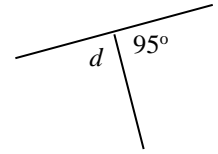
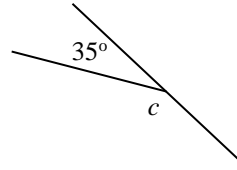
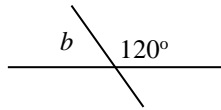
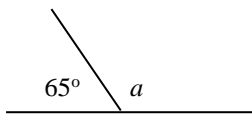

2. Calculate the size of each missing angle in the triangles below:

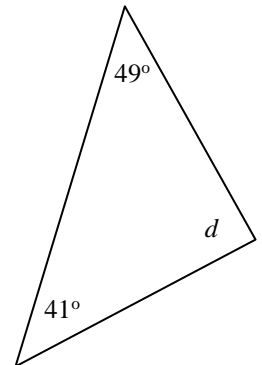
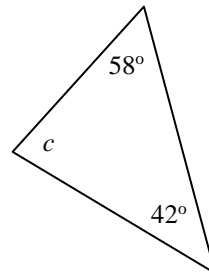
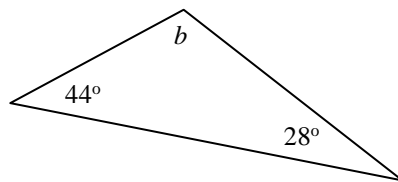
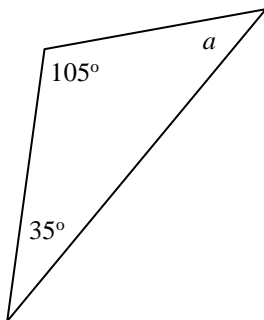

3. Copy each triangle below and fill in all the missing angles:

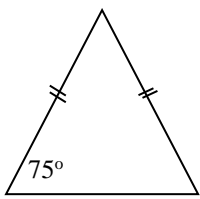

(a)

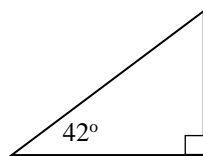

(b)

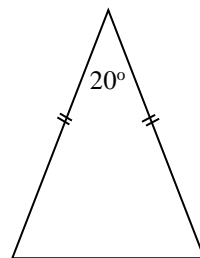

(c)

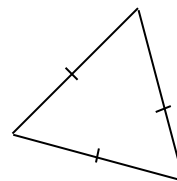

(d)

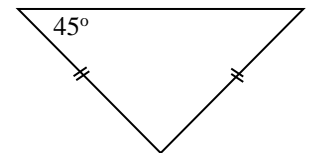

(e)

4. Copy these diagrams and fill in the sizes of all the missing angles.

(a)

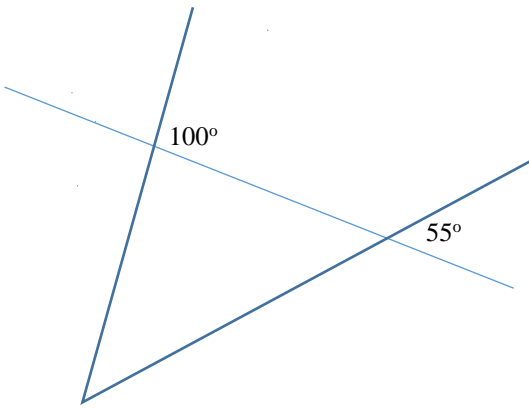

(b)

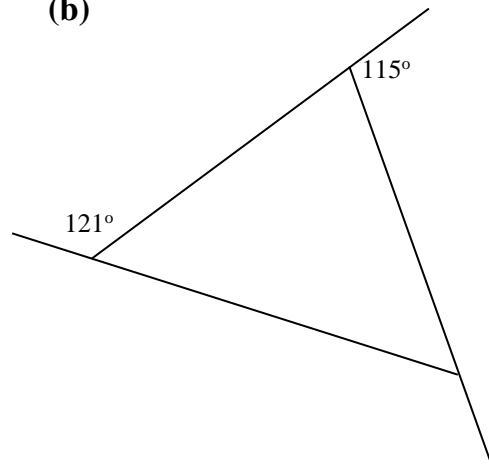

(c)

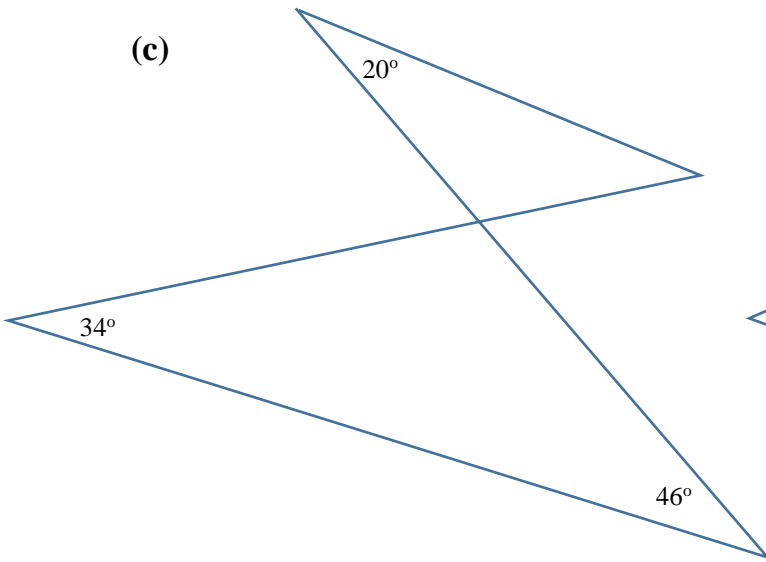

(d)

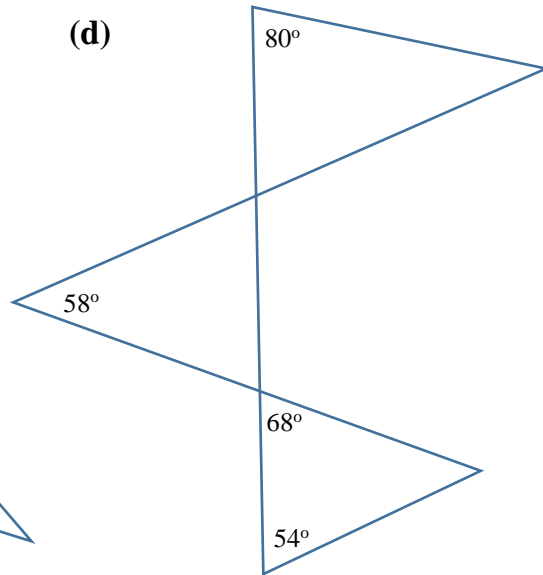

(e)

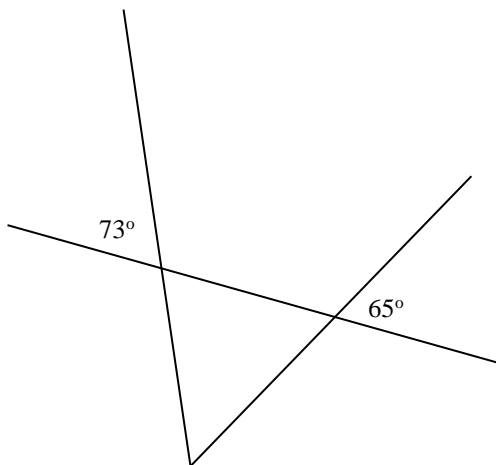

(f)

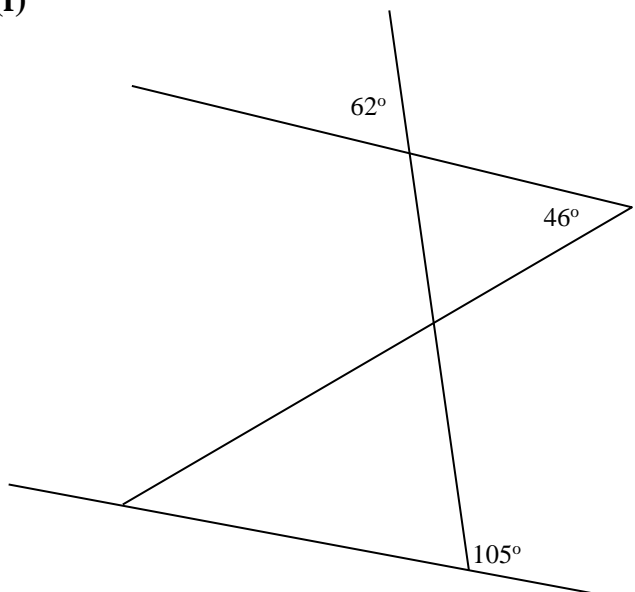

Applying Geometric Skills to Sides and Angles of a Shape

Using Parallel Lines, Symmetry and Circle Properties to Calculate Angles

PART 1

1. Calculate the sizes of the angles marked with letters in these diagrams.

(a)

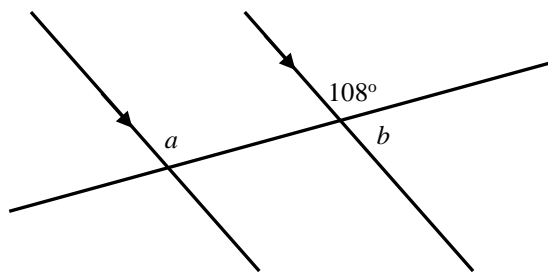

(b)

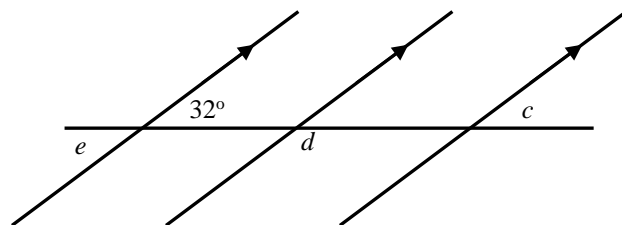

(c)

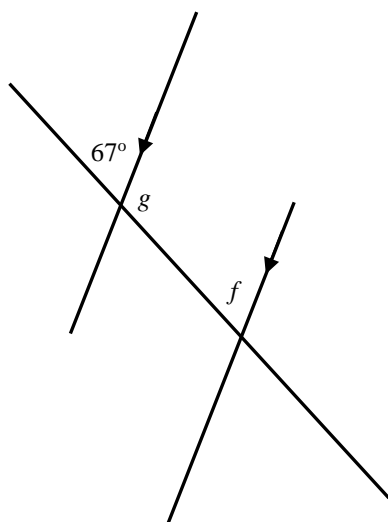

(d)

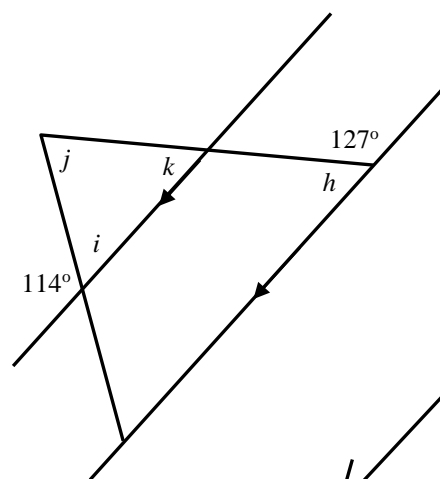

(e)

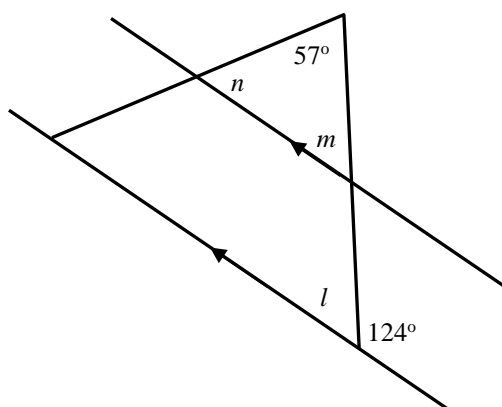

(f)

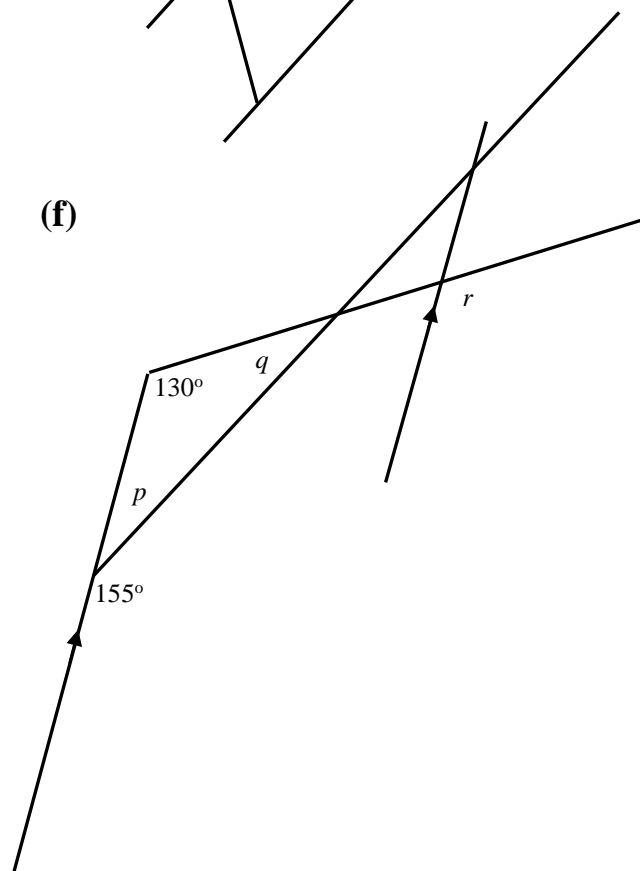

2. Calculate the sizes of the angles marked a to i in these diagrams.

(a)

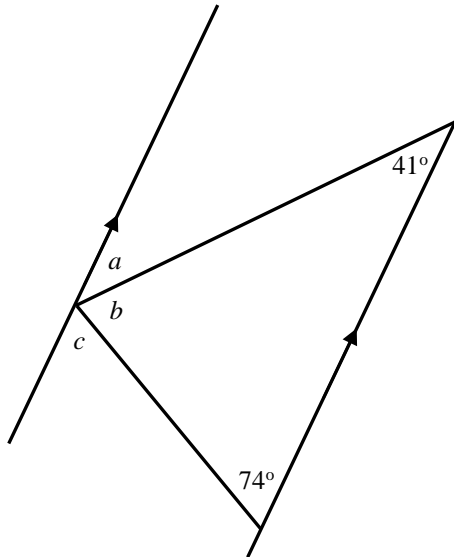

(b)

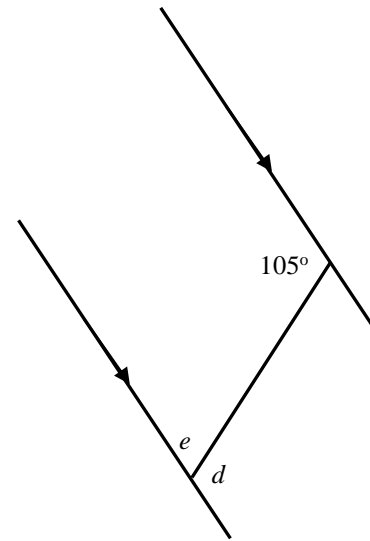

(c)

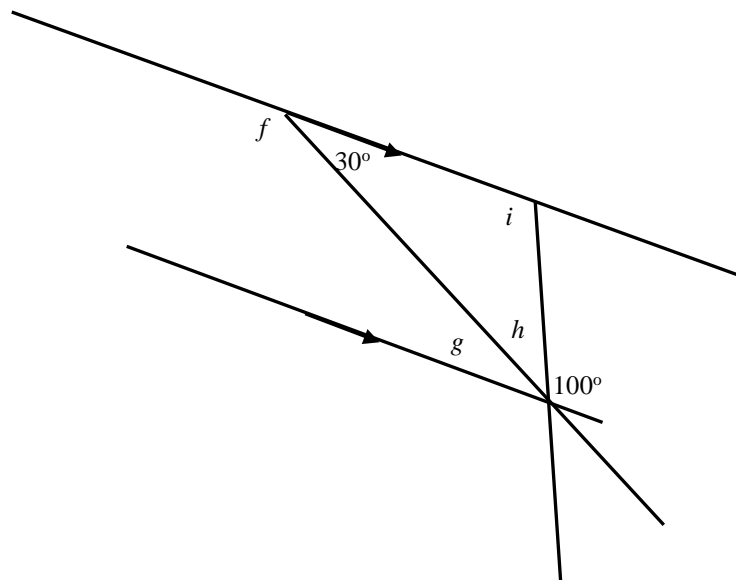

3. Calculate the sizes of the angles marked a to h in these diagrams.

(a)

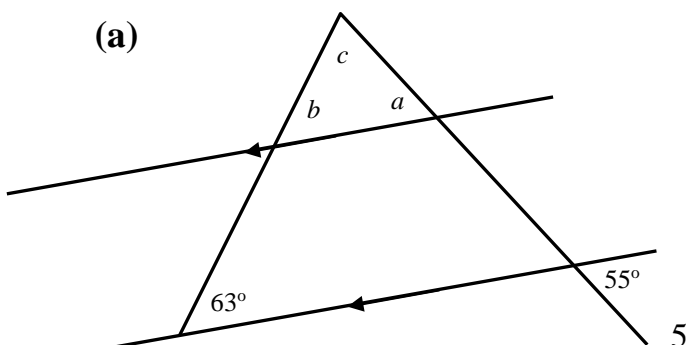

(b)

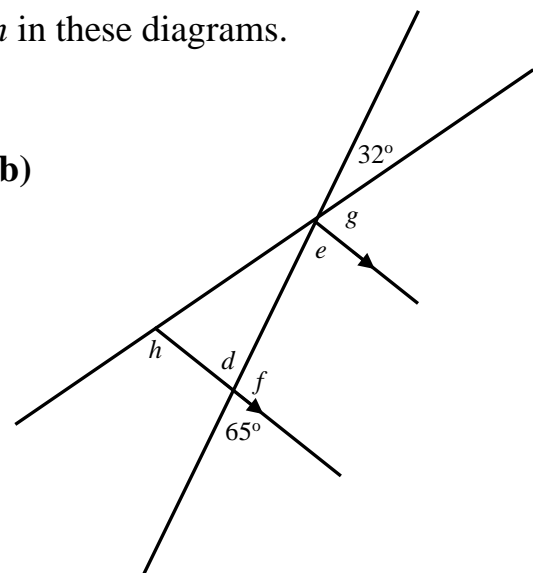

4. Calculate the sizes of the angles marked a to f in these diagrams.

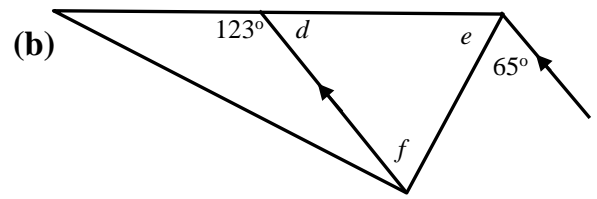
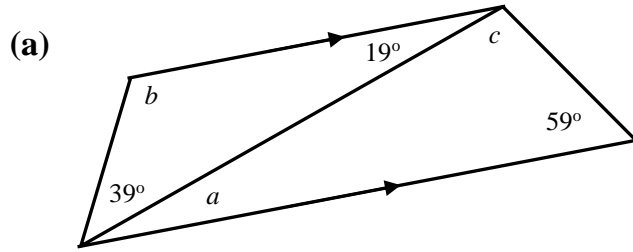

5. Copy these diagrams and fill in the sizes of as many angles as you can.

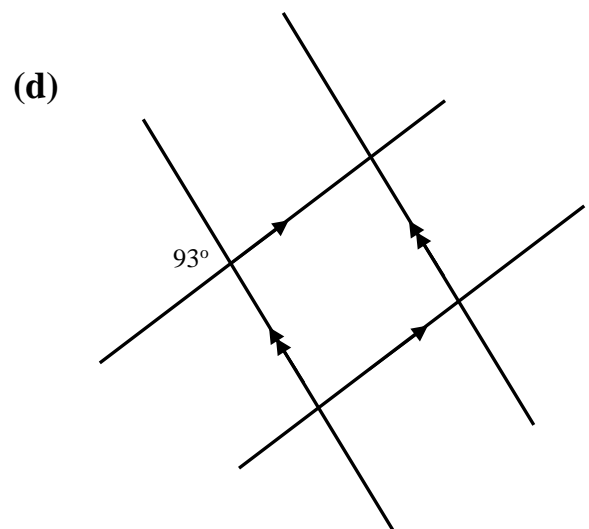
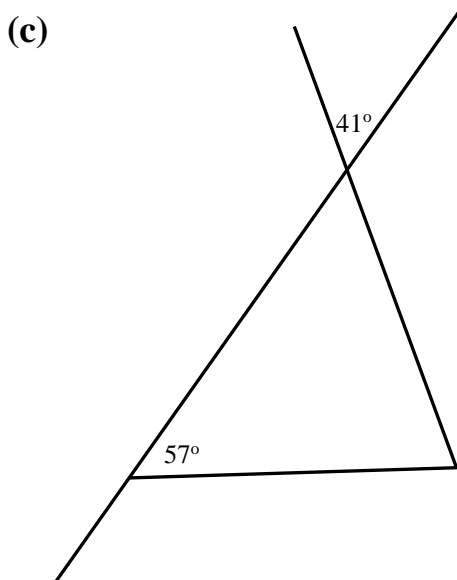
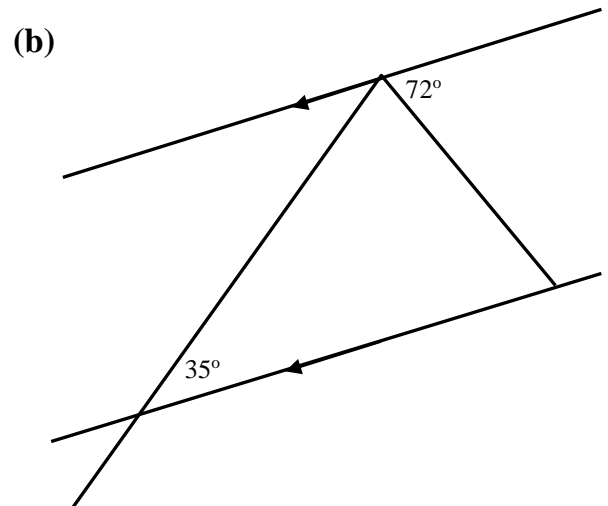
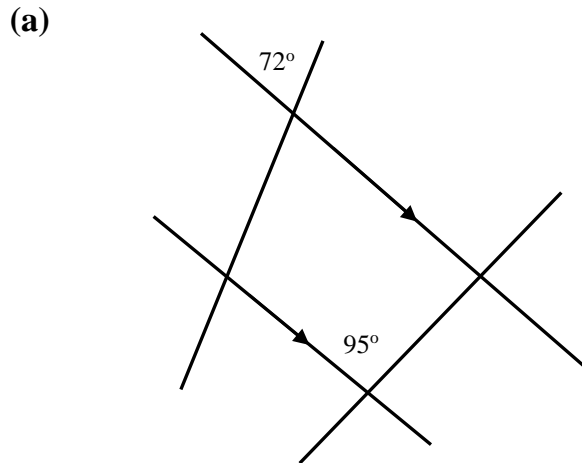

6. Find the value of x in each of these diagrams:

(a)

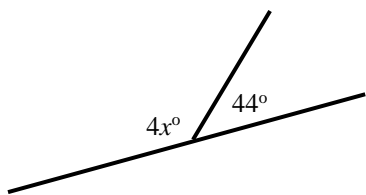

(b)

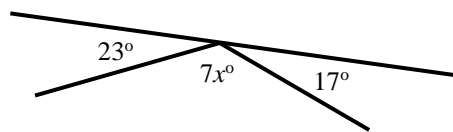

(c)

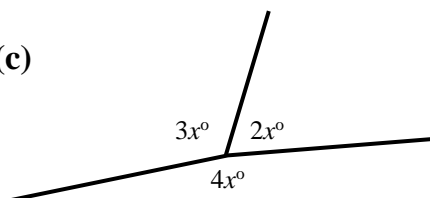

(d)

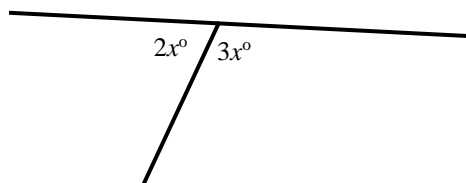

(e)

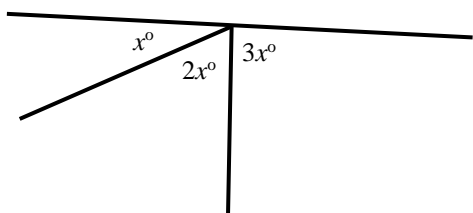

(f)

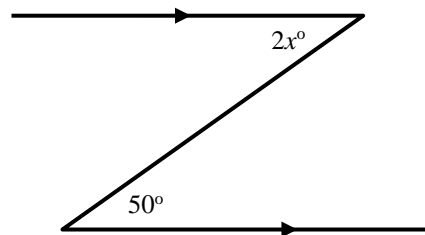

(g)

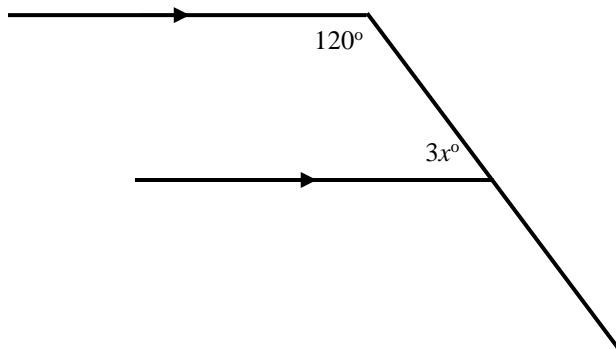

(h)

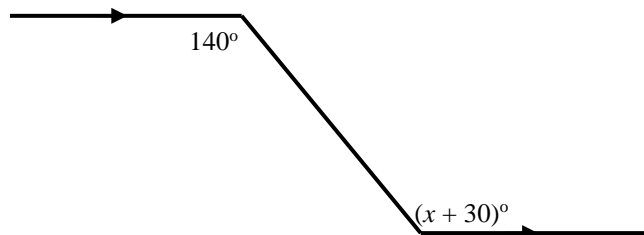

Applying Geometric Skills to Sides and Angles of a Shape

Using Parallel Lines, Symmetry and Circle Properties to Calculate Angles

PART 2

- marks the centre of each circle

1. Calculate the size of each of the angles marked with letters in the diagrams below.

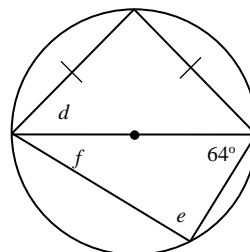
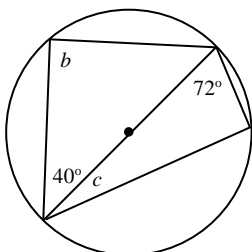
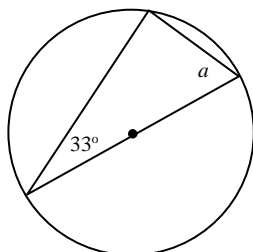

2. In each of the diagrams below AB is a diameter. Find the missing angles in each diagram.

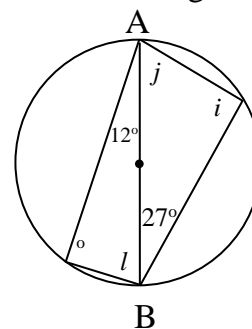
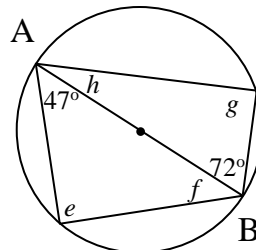
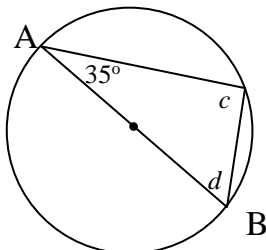
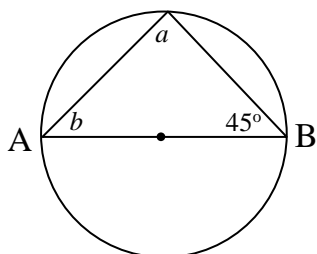

3. Calculate the sizes of the angles marked a, b, \dots, n , in the diagrams below.

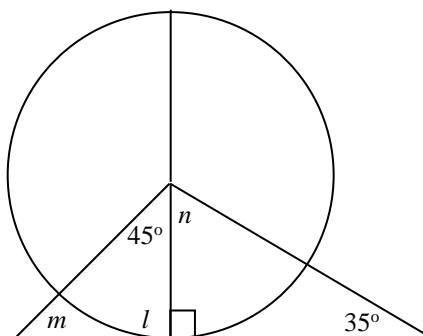
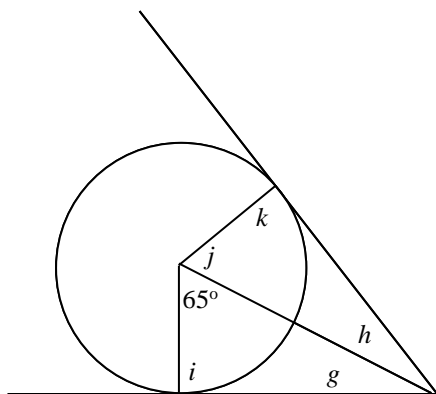
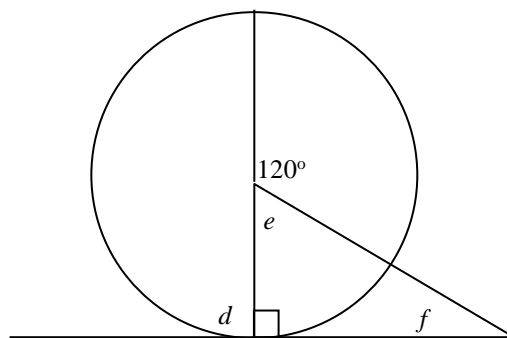
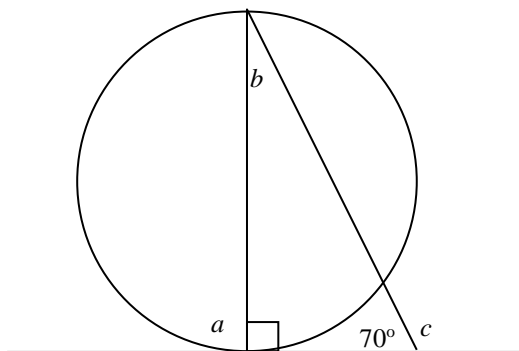

Angles

1. $a = 115^\circ$ $b = 60^\circ$ $c = 145^\circ$ $d = 85^\circ$ $e = 100^\circ$

$f = 75^\circ$ $g = 112^\circ$ $h = 38^\circ$ $i = 142^\circ$ $j = 85^\circ$

$k = 95^\circ$ $l = 85^\circ$ $m = 32^\circ$ $n = 32^\circ$ $p = 148^\circ$

2. $a = 40^\circ$ $b = 108^\circ$ $c = 80^\circ$ $d = 90^\circ$

3. (a) $75^\circ/30^\circ$ (b) 48° (c) both 80°

(d) all 60° (e) $45^\circ/90^\circ$

4. (a)

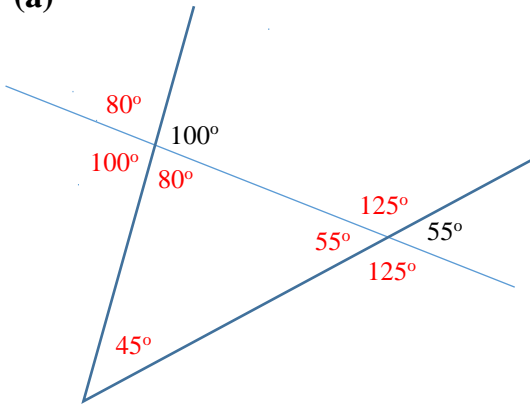

(b)

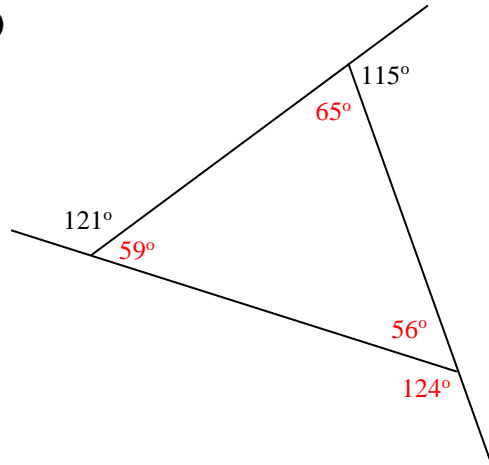

(c)

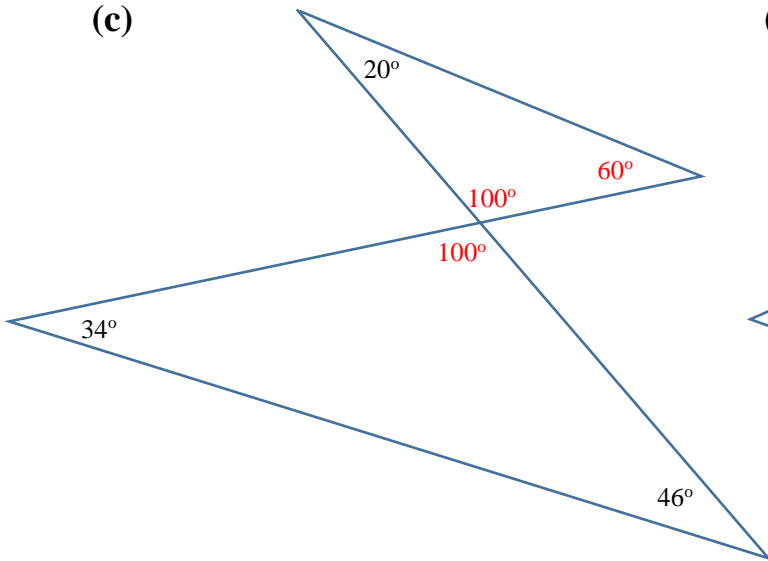

(d)

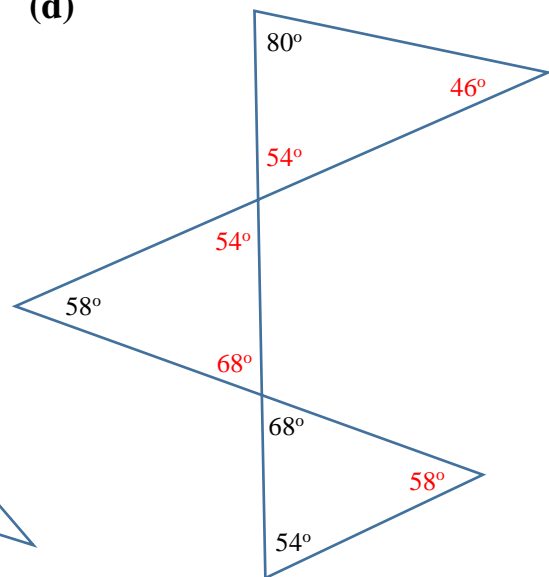

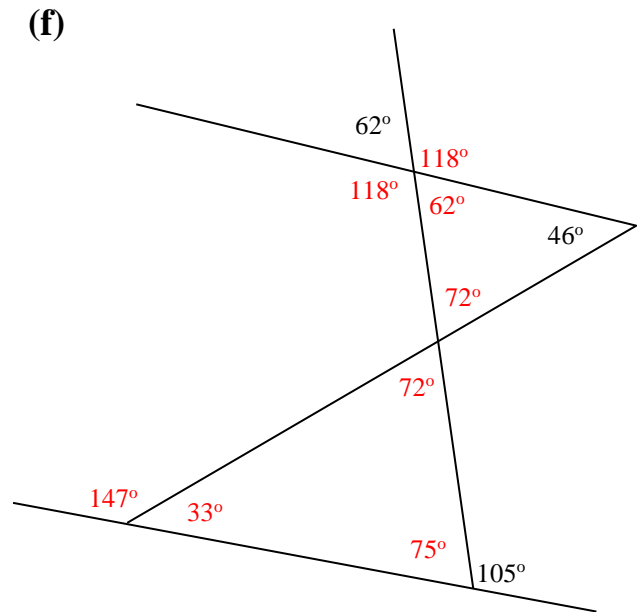
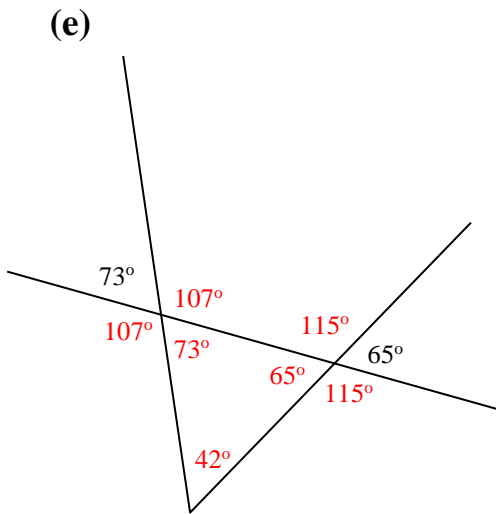

Applying Geometric Skills to Sides and Angles of a Shape

Using Parallel Lines, Symmetry and Circle Properties to Calculate Angles

PART 1

1. (a) $a = 108^\circ$ $b = 72^\circ$
 (b) $c = 32^\circ$ $d = 148^\circ$ $e = 32^\circ$
 (c) $f = 67^\circ$ $g = 113^\circ$
 (d) $h = 53^\circ$ $i = 66^\circ$ $j = 61^\circ$ $k = 53^\circ$
 (e) $l = 56^\circ$ $m = 56^\circ$ $n = 67^\circ$
 (f) $p = 25^\circ$ $q = 25^\circ$ $r = 130^\circ$
2. (a) $a = 41^\circ$ $b = 65^\circ$ $c = 74^\circ$
 (b) $d = 105^\circ$ $e = 75^\circ$
 (c) $f = 150^\circ$ $g = 30^\circ$ $h = 50^\circ$ $i = 100^\circ$
3. (a) $a = 55^\circ$ $b = 63^\circ$ $c = 62^\circ$
 (b) $d = 65^\circ$ $e = 65^\circ$ $f = 115^\circ$ $g = 83^\circ$ $h = 97^\circ$
4. (a) $a = 19^\circ$ $b = 122^\circ$ $c = 102^\circ$
 (b) $d = 57^\circ$ $e = 58^\circ$ $f = 65^\circ$

5. (a)

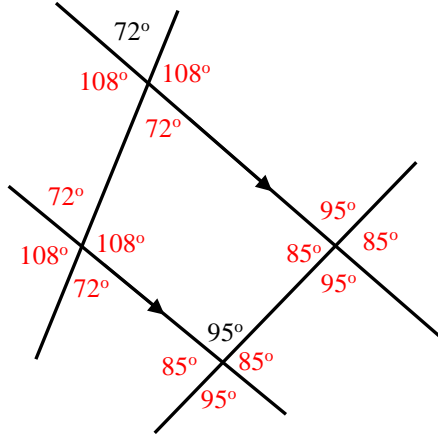

(b)

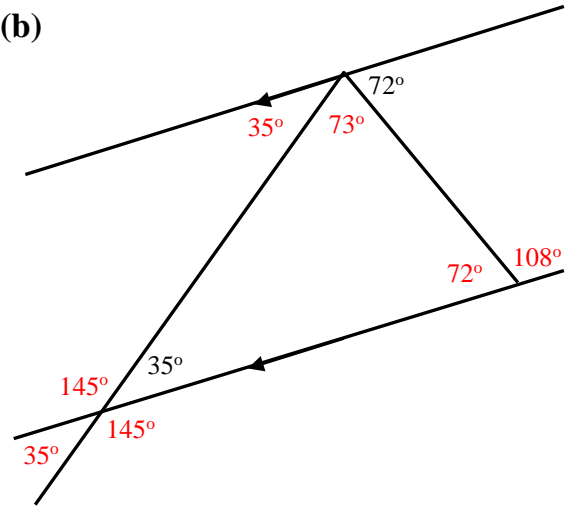

(c)

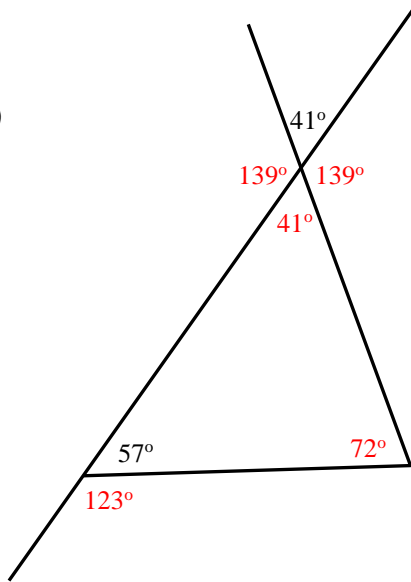

(d)

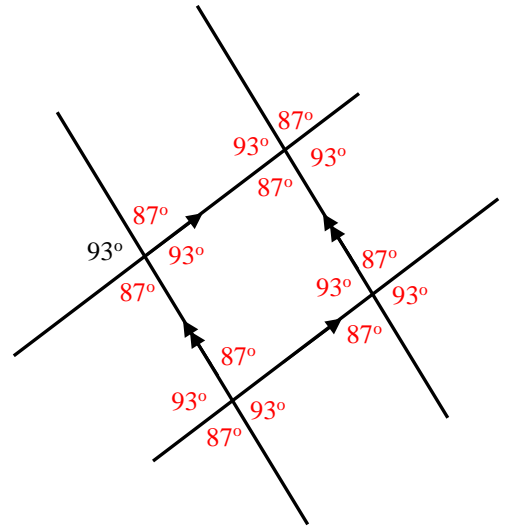

6. (a) 34° (b) 20° (c) 40° (d) 36° (e) 30° (f) 25°
 (g) 20° (h) 110°

Applying Geometric Skills to Sides and Angles of a Shape

Using Parallel Lines, Symmetry and Circle Properties to Calculate Angles

PART 2

1. $a = 57^\circ$ $b = 90^\circ$ $c = 18^\circ$ $d = 45^\circ$ $e = 90^\circ$ $f = 26^\circ$

2. $a = 90^\circ$ $b = 45^\circ$ $c = 90^\circ$ $d = 55^\circ$ $e = 90^\circ$ $f = 43^\circ$

$g = 90^\circ$ $h = 18^\circ$ $i = 90^\circ$ $j = 63^\circ$ $k = 90^\circ$ $l = 78^\circ$

3. $a = 90^\circ$ $b = 20^\circ$ $c = 110^\circ$ $d = 90^\circ$ $e = 60^\circ$ $f = 30^\circ$

$g = 25^\circ$ $h = 25^\circ$ $i = 90^\circ$ $j = 65^\circ$ $k = 90^\circ$ $l = 90^\circ$

$m = 45^\circ$ $n = 55^\circ$