

# SOH-CAH-TOA

1. In the diagram  
 Angle  $STV = 34^\circ$   
 Angle  $VSW = 25^\circ$   
 Angle  $SVT = \text{Angle } SWV = 90^\circ$   
 $ST = 13.1$  centimetres  
 Calculate the length of  $SW$

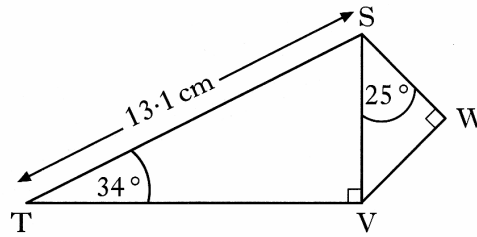

4 KU

2. A cat is trapped in a tree and a ladder is placed against the tree in an attempt to rescue it.

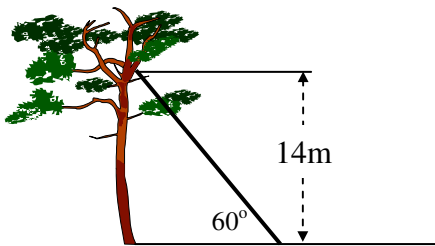

The ladder rests against the tree making an angle of  $60^\circ$  with the horizontal and reaching 14 metres up the tree, allowing the rescuer to reach the cat.

Just as the cat is about to be rescued, it jumps to a branch 1 metre above its original resting place.

Calculate the size of the angle, to the nearest degree, that the ladder now has to make with the horizontal to allow the rescuer to reach the cat.

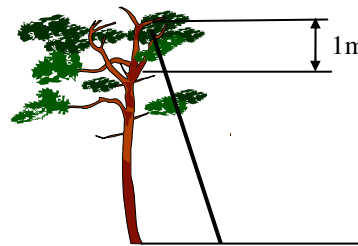

5 RE

3. The owners of Stately Hall Manor erected an entrance ramp for disabled people at the main front entrance.

Local building regulations state that ramps must be built at an angle of **not more than**  $15^\circ$  to the horizontal ground.

A side view of the ramp which was actually erected is shown above.

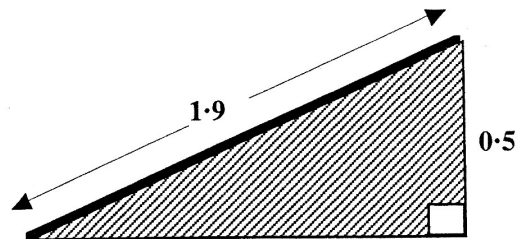

Does this ramp satisfy the local building regulations ?

**You must explain your answer with mathematical reasoning.**

4 RE

4. Two support cables, from the top (T) of a motorway light, are attached to a pair of points, A and B, on the ground, as shown in the diagram.

- a) Calculate the distance from B to C.  
 b) Calculate the distance from A to B.

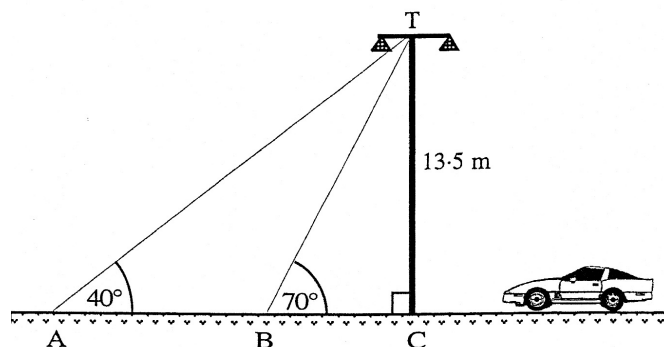

2 KU

3 RE

5. A statue stands at the corner of a square courtyard.

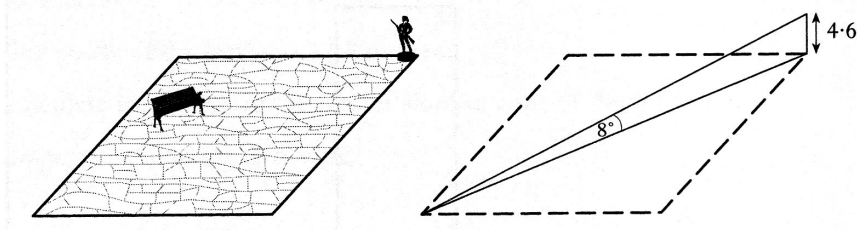

The statue is 4.6 metres high.

The angle of elevation from the opposite corner of the courtyard to the top of the statue is  $8^\circ$ .

- a) Find the distance from the base of the statue to the opposite corner of the courtyard. 2 RE
- b) Show that the length of the side of the courtyard is approximately 23 metres. 2 RE

6. The diagram shows the design of an earring.

The earring consists of a circle inside an equilateral triangle.

The sides of the triangle are tangents to the circle.

The radius of the circle is 8 mm

The distance from the centre of the circle to **each** vertex of the triangle is 16 mm.

Calculate the perimeter of the triangle.

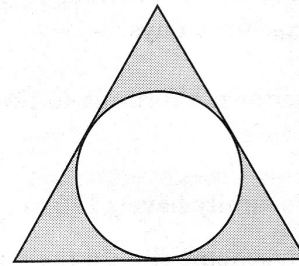

4 RE

7. The Scott family want to build a conservatory as shown in the diagram.

The conservatory is to be 3 metres wide.

The height of the conservatory at the lower end is to be 2 metres and at the higher end 3.5 metres.

To obtain planning permission, the roof must slope at an angle of  $(25 \pm 2)$  degrees to the horizontal.

Should planning permission be granted.

**Justify your answer.**

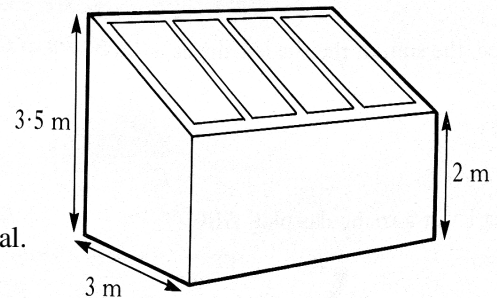

4 RE

8. The diagram shows the design of a swimming pool 50 metres in length.

The pool is 1 metre deep at one end and its base slopes downwards at an angle of  $3^\circ$  to the horizontal.

Calculate the depth,  $d$  metres, of the other end of the pool, giving your answer to 2 significant figures.

**Do not use a scale drawing.**

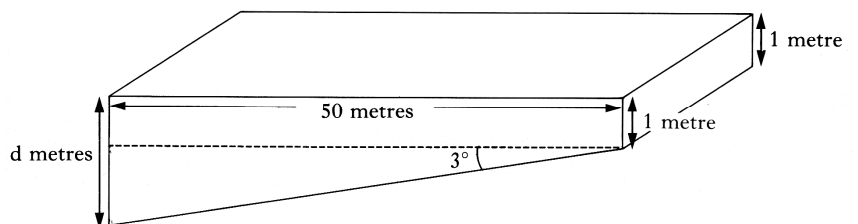

5 KU